

Model 742HW-CT (hot well/counter-top) is the perfect complement to Thermodyne's hot well models which feature our patented cook, hold, and rethermalizing cabinet beneath the wells. This compact counter-top design allows users to double or triple their hot well capacity, when kitchen floor space is limited. The model 742HW-CT is a dry well, meaning no water is required to provide heat in the wells. Not having to use water allows for easier clean up at the end of the day. Additionally, each well has individual temperature controls enabling the user to hold foods at different temperatures across the wells.



SPECIFICATIONS	
EXTERIOR DIMENSIONS	30.50"W x 33.00"D x 15.125"H
MAX OPERATING TEMP	350°F
NET WEIGHT	145lbs.
SHIPPING WEIGHT	245lbs.

ELECTRICAL SPECIFICATIONS	
VOLTS	208 / 240
AMPS	8 / 9
TOTAL WATTS	1664 / 2160
HERTZ	60
PHASE	1
PLUG	NEMA 6-15

CAPACITIES	STANDARD	MAXIMUM*
STEAM TABLE PAN		
12" x 20" x 6"	2	2

STANDARD ACCESSORIES	
Extended Base	1/3 Size Insert Plate & 1/4 Size Insert Plate
Extended Lid	
Controller Shield	

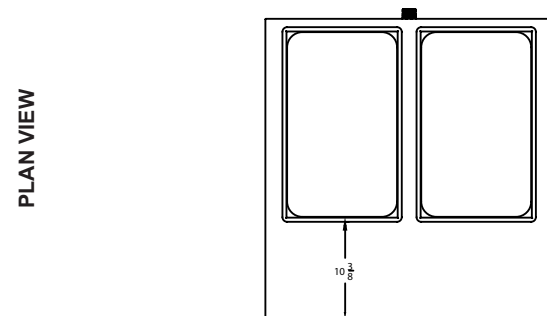
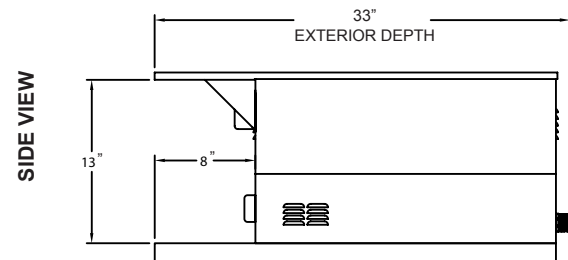
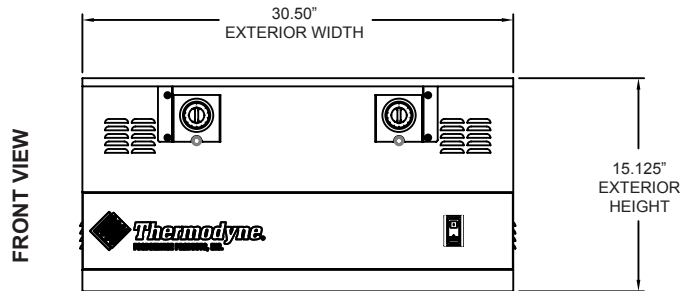

Specifications subject to change without notice.

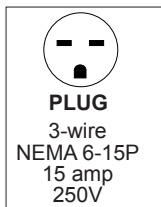

Patented

REV. 07/17