

The high performance 700DP creates a revolutionary concept in automated foodservice equipment. With Thermodyne's 700DP, it is now possible to refrigerate, automatically reheat and hold prepared foods, with no food service attendant required. The 700DP can be custom programmed for different meal times for every day of the week.

SPECIFICATIONS	
EXTERIOR DIMENSIONS	35.00"W x 29.56"D x 51.25"H
INTERIOR DIMENSIONS	26.50"W x 25.00"D x 22.75"H
CUBIC CAPACITY	8.70ft ³
MIN OPERATING TEMP	36°F
MAX OPERATING TEMP	230°F
NET WEIGHT	432lbs.
SHIPPING WEIGHT	510lbs.

ELECTRICAL SPECIFICATIONS	
VOLTS	208 / 240
AMPS	26 / 30
TOTAL WATTS	5438 / 7250
HERTZ	50 / 60
PHASE	1
PLUG	NEMA L14-30

SHELVES	
STANDARD	5

CAPACITIES	
SHEET PAN	
18" x 26" x 1"	5
STEAM TABLE PAN	
12" x 20" x 2.5"	10

Specifications subject to change without notice.

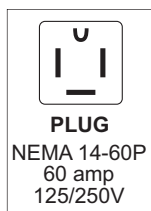
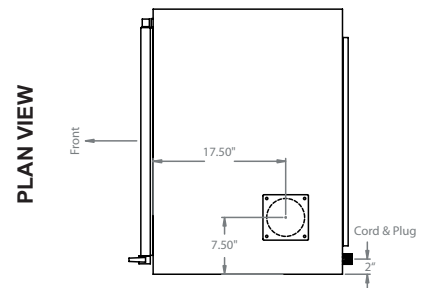
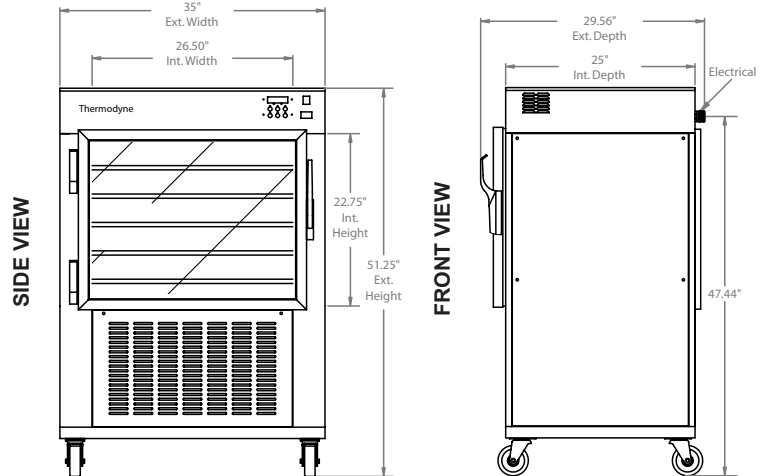

UL 197 Compliant
 01/07 Patented

The high performance 1500DP creates a revolutionary concept in automated foodservice equipment. With Thermodyne's 1500DP, it is now possible to refrigerate, automatically reheat and hold prepared foods, with no food service attendant required. The 1500DP can be custom programmed for different meal times for every day of the week.

SPECIFICATIONS	
EXTERIOR DIMENSIONS	35.00"W x 29.56"D x 74.50"H
INTERIOR DIMENSIONS	26.50"W x 25.00"D x 45.50"H
CUBIC CAPACITY	17.44ft ³
MIN OPERATING TEMP	36°F
MAX OPERATING TEMP	230°F
NET WEIGHT	583lbs.
SHIPPING WEIGHT	660lbs.

ELECTRICAL SPECIFICATIONS	
VOLTS	208 / 240
AMPS	52 / 59
TOTAL WATTS	10688 / 14250
HERTZ	50 / 60
PHASE	1
PLUG	NEMA 14-60P

SHELVES	
STANDARD	10

CAPACITIES	
SHEET PAN	
18" x 26" x 1"	10
STEAM TABLE PAN	
12" x 20" x 2.5"	10

Specifications subject to change without notice.

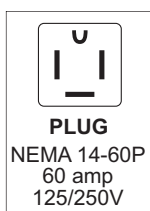

UL 197 Compliant

01/07 Patented

