

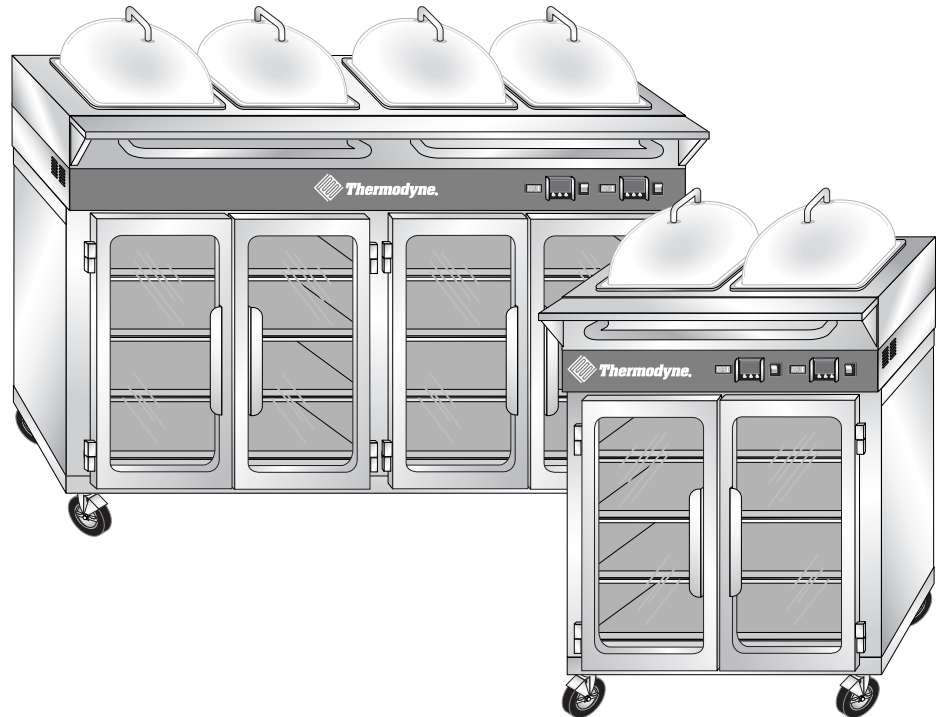

INSTALLATION & OPERATION MANUAL



MODELS

742HW

744HW

For additional information on Thermodyne Foodservice Products, Inc.,
or to locate an authorized parts and service provider in your area,
visit our website at www.tdyne.com

Thermodyne Foodservice Products, Inc.
4418 New Haven Avenue
Fort Wayne, IN 46803

1-800-526-9182
www.tdyne.com

IMPORTANT FOR YOUR SAFETY

THIS MANUAL HAS BEEN PREPARED FOR PERSONNEL QUALIFIED TO INSTALL ELECTRICAL EQUIPMENT, WHO SHOULD PERFORM THE INITIAL FIELD STARTUP AND ADJUSTMENTS OF THE EQUIPMENT COVERED BY THIS MANUAL.

READ THIS MANUAL THOROUGHLY BEFORE OPERATING, INSTALLING OR PERFORMING MAINTENANCE ON THE EQUIPMENT.

⚠ WARNING: Failure to follow all the instructions in this manual can cause property damage, injury or death.

⚠ WARNING: Improper installation, adjustment, alteration, service or maintenance can cause property damage, injury or death.

⚠ WARNING: Electrical connections should be performed only by a certified professional.

⚠ WARNING: Electrical and grounding connections must comply with the applicable portions of the National Electric Code and/or all local electric codes. Failure to comply with this procedure can cause property damage, injury or death.

⚠ WARNING: Before connecting the unit to the electrical supply, verify that the electrical and grounding connections comply with the applicable portions of the National Electric Code and/or other local electrical codes. Failure to comply with this procedure can cause property damage, injury or death.

⚠ WARNING: Before connecting the unit to the electrical supply, verify that the electrical connection agrees with the specifications on the data plate. Failure to comply with this procedure can cause property damage, injury or death.

⚠ WARNING: UL73 grounding instructions: This appliance must be connected to a grounded, metal, permanent wiring system. Or an equipment-grounding conductor must be run with the circuit conductors and connected to the equipment-grounding terminal or lead on the appliance. Failure to comply with this procedure can cause property damage, injury or death.

⚠ WARNING: Appliances equipped with a flexible electric supply cord, are provided with a three-prong grounding plug. It is imperative that this plug be connected into a properly grounded three-prong receptacle. Failure to comply with this procedure can cause property damage, injury or death.

⚠ WARNING: If the receptacle is not the proper grounding type, contact an electrician. Do not remove the grounding prong from the plug. Failure to comply with this procedure can cause property damage, injury or death.

⚠ WARNING: Before performing any service that involves electrical connection or disconnection and/or exposure to electrical components, always perform the Electrical LOCKOUT/TAGOUT Procedure. Disconnect all circuits. Failure to comply with this procedure can cause property damage, injury or death.

⚠ WARNING: Before removing any sheet metal panels or servicing this equipment, always perform the Electrical LOCKOUT/TAGOUT Procedure. Be sure all circuits are disconnected. Failure to comply with this procedure can cause property damage, injury or death.

⚠ WARNING: Do not operate this equipment without properly placing and securing all covers and access panels. Failure to comply with this procedure can cause property damage, injury or death.

⚠ WARNING: Do not use or store gasoline or other flammable vapors or liquids in the vicinity of this or any other appliance. Failure to comply can cause property damage, injury or death.

⚠ WARNING: In the event of a power failure, do not attempt to operate this appliance. Failure to comply can cause property damage, injury or death.

CAUTION: These models have glass doors. Remove carton carefully.

FOR YOUR SAFETY

DO NOT STORE OR USE GASOLINE OR OTHER FLAMMABLE VAPORS OR LIQUIDS IN THE VICINITY OF THIS OR ANY OTHER APPLIANCE. FAILURE TO COMPLY CAN CAUSE PROPERTY DAMAGE, INJURY OR DEATH.

TABLE OF CONTENTS

IMPORTANT FOR YOUR SAFETY.....	2
INTRODUCTION	5
GENERAL	5
SPECIFICATIONS	5
UNPACKING.....	7
Thermodyne Damaged Goods Policy.....	7
INSTALLATION CODES AND STANDARDS	7
INSTALLATION.....	8
LOCATION.....	8
ELECTRICAL CONNECTION	8
ELECTRICAL SPECIFICATIONS.....	8
OPERATION.....	9
CONTROLS AND INDICATORS.....	9
STARTUP	9
Setting Temperature.....	10
Preheating	10
FLUID REPLENISHMENT.....	10
CLEANING AND MAINTENANCE	12
ELECTRICAL LOCKOUT/TAGOUT PROCEDURE.....	12
WHEN TO CLEAN	12
STAINLESS STEEL CARE.....	12
Cleaning.....	12
Preserving & Restoring.....	12
Heat Tint	13
CLEANING HEAT TRANSFER PLATES.....	13
CLEANING DOOR GASKETS	13
CHANGING FLUID.....	13
TROUBLESHOOTING.....	16
SCHEMATIC WIRING DIAGRAM.....	17
WARRANTY	18
HEAT TRANSFER FLUID MSDS	18

INTRODUCTION

GENERAL

Thermodyne cabinets are produced with quality workmanship and materials. Proper installation, operation and maintenance will result in many years of satisfactory performance. It is suggested that you thoroughly read this manual in its entirety

and carefully follow all of the instructions provided. The cabinets described in this manual are programmable for the desired holding temperature. The factory setting is 185° F unless otherwise specified. Each shelf in the cabinet maintains an exact temperature, allowing for extended holding times without sacrificing appearance or taste.

SPECIFICATIONS

DIMENSIONS AND MAXIMUM TEMPERATURE							
Model	Ext. Width inches	Ext. Depth inches	Ext. Height inches	Int. Width inches	Int. Depth inches	Int. Height inches	Max Oper. Temp °F
742HW	30.50	30.94	40.50	26.50	22.50	20.00	230
744HW	60.00	30.94	40.50	56.00	22.50	20.00	230

WEIGHT		
Model	Net Weight lbs	Shipping Weight lbs
742HW	265	340
744HW	470	560

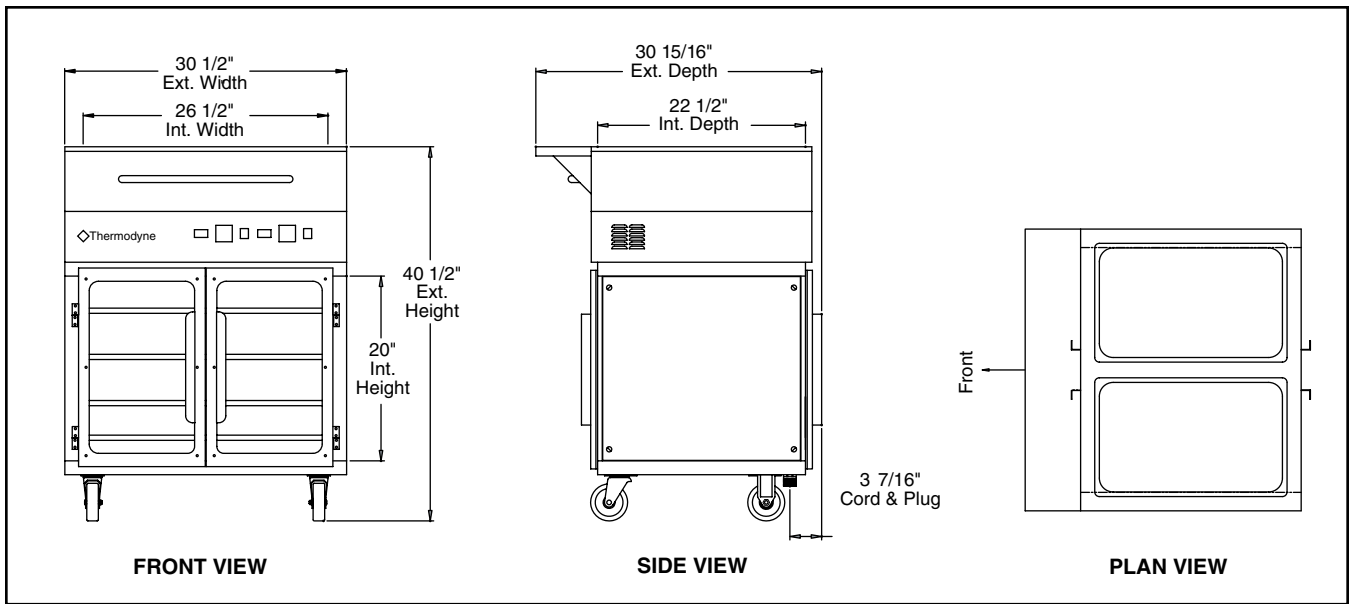

Figure 1: Outline Dimensional Drawing, 742HW

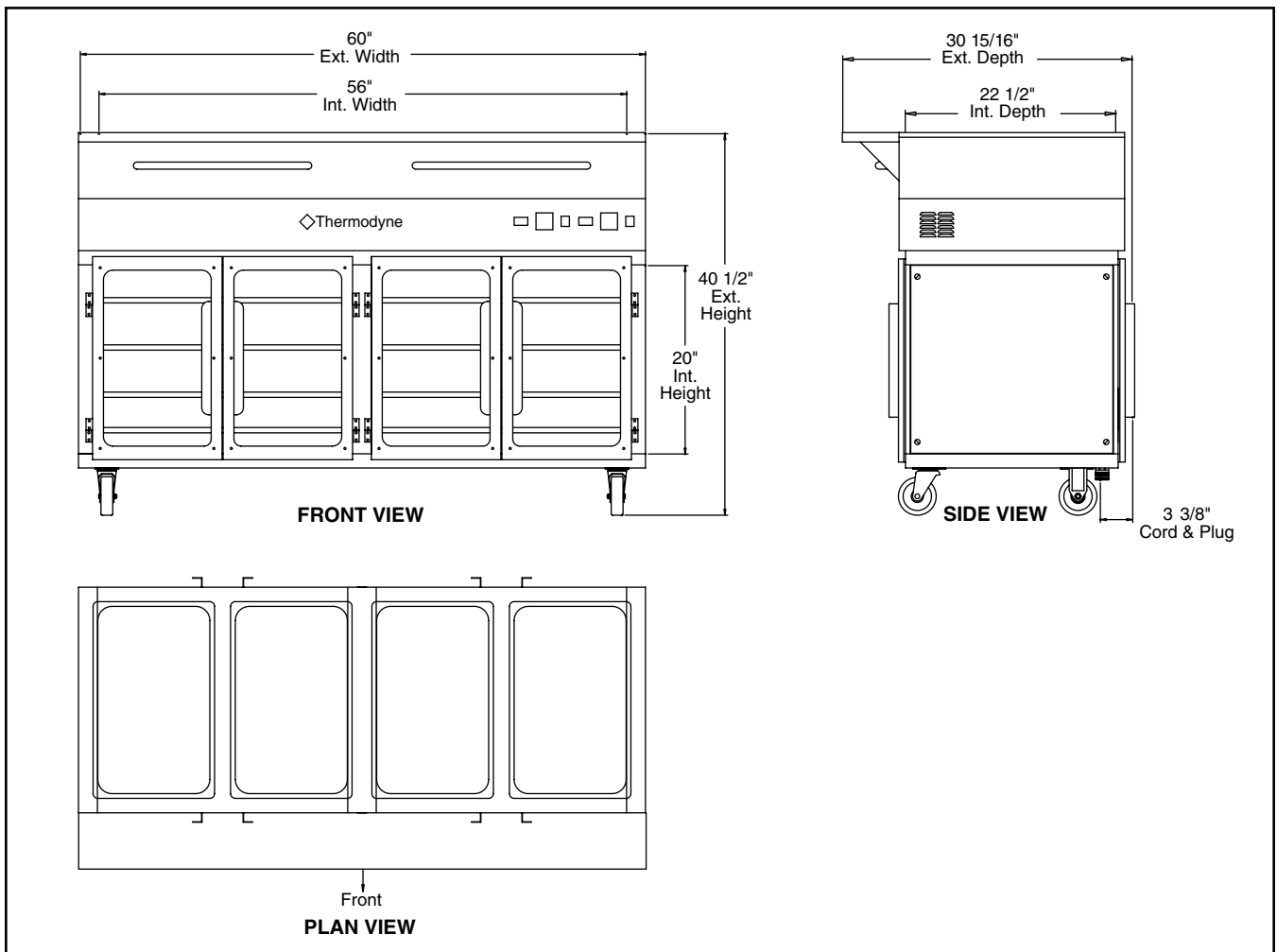

Figure 2: Outline Dimensional Drawing, 744HW

UNPACKING

All Thermodyne cabinets are factory tested for performance and certified free from defects.

Thermodyne Damaged Goods Policy

There are two types of damaged merchandise: A. Visible Damage and B. Concealed Damage.

A. Visible Damage: The product being received is visibly damaged.

1. The receiver should refuse the damaged merchandise.
2. Receiver should sign the bill of lading indicating which merchandise is being refused due to damage.
3. Contact Thermodyne Customer Service Representatives immediately.

B. Concealed Damage: Damaged merchandise cannot be externally detected.

Your receiving operation should inspect for this type of damage. Please inspect your delivery carefully.

If the product is damaged:

1. Save all packing material.
2. Contact Thermodyne Customer Service Representatives immediately.
3. Receiver must call the carrier to schedule an inspection of the damaged merchandise within 5 business days.

INSTALLATION CODES AND STANDARDS

These installation instructions are for the use of **qualified installation and service personnel only**.

1. Installation or service by other than qualified personnel may result in damage to the Thermodyne cabinet and/or injury to the operator.
2. National Electrical Code (ANSI/NFPA No. 70, latest edition) available from the National Fire Protection Association, Batterymarch Park, Quincy, MA 02269.

In Canada, the cabinet must be installed in accordance with:

1. Local codes.
2. Canadian Electrical Code (CSA C22.2 No. 3, latest edition) available from the Canadian Standards Association, 5060 Spectrum Way, Mississauga, Ontario, Canada L4W 5N6.

INSTALLATION

Before installing, verify the required electrical supply agrees with the specifications on the data plate located on the back or side of the unit. If the supply and equipment requirements do not agree, do not proceed with installation. Contact your dealer or Thermodyne Foodservice Products, Inc. immediately.

CAUTION: These models have glass doors. Remove carton carefully.

1. Allow ample overhead clearance for removal of carton.
2. Cut banding (2 pieces) and remove nails (not for all units).
3. To remove cabinet from carton, slide carton up and off the cabinet.
4. Check packing list against items received:
 - A. Thermodyne Heat Transfer Fluid
 - B. Installation & Operation Manual
5. Use proper lifting equipment to raise the cabinet.
6. Remove the plastic covering from glass door frames and hinges.
7. Mount doors on cabinet, and then check doors for alignment.
8. Set cabinet on a level surface.

LOCATION

Allow adequate space for electrical connections. The electrical cord and plug are located at the right rear of the unit. The minimum clearance for proper air circulation on back should be 4", and 2" on at least one side. Allow adequate access space for operating and servicing the unit.

NOTICE: Louvers on the sides of the oven are used to circulate cool air throughout the electrical components. The unit must not be placed where extensive airborne grease is present, such as near deep fryers or griddles.

ELECTRICAL CONNECTION

⚠ WARNING: Electrical and grounding connections must comply with applicable portions of the National Electrical Code and/or other local electrical codes.

⚠ WARNING: Disconnect the electrical power to the Thermodyne unit and follow LOCKOUT/TAGOUT procedures.

Refer to the wiring diagrams in this manual for wiring information.

ELECTRICAL SPECIFICATIONS

MODEL	VOLTS	AMPS	WATTS	HERTZ	PHASE	PLUG
742HW	208/240	16/19	3375/4500	60	1	NEMA 14-30
744HW*	208/240	32/37	6750/9000	60	1	NEMA 14-30*

* Two (2) plugs required for this unit.

OPERATION

CONTROLS AND INDICATORS

All controls are located at the top right front of the Thermodyne cabinet:

- The control closest to the cabinet's right side controls the oven
- The control to the left of the oven control is for the hot wells.

ITEM	FUNCTION
ON/OFF Switch	When lit, it indicates the unit is turned on.
ADD FLUID Light (Red)	When lit, it indicates additional fluid is required.
Controller	Provides readout of actual temperature and desired temperature. It has increase and decrease buttons for setting the desired temperature. In addition, a red OUT light blinks indicating the desired temperature is being maintained.

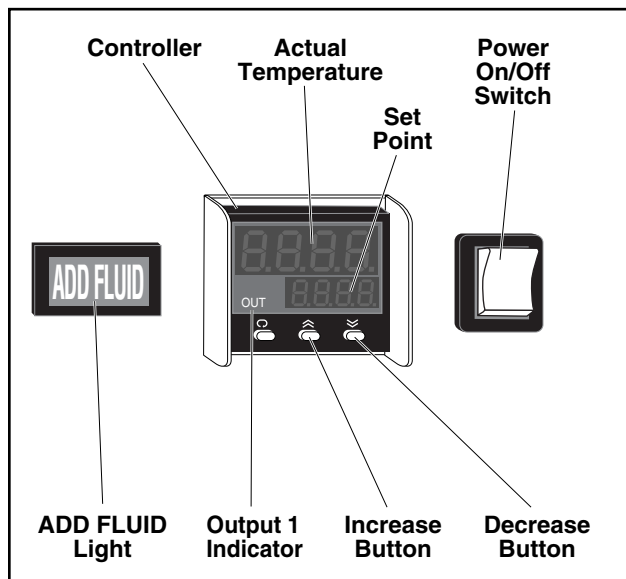

Figure 3: Control Panel

STARTUP

⚠ WARNING: The oven cabinet and hot wells are hot. Use care when operating, cleaning or servicing this equipment.

Once the cabinet is installed and electrical connections have been made, thoroughly test the Thermodyne cabinet before operation.

1. Check that all packing materials and other items have been removed from the cabinet.
2. Press the Power ON/OFF Switches to the ON position. The operating temperature will be reached in approximately 30 minutes.
3. Check ADD FLUID Light.
 - **OVEN CONTROL:** If the light remains on or flickers continuously, it indicates that some fluid was lost during shipment. Add fluid as described in the section FLUID REPLENISHMENT.
 - **HOT WELL CONTROL:** The light will come on if there is no water in at least one of the wells or the water drops below the water level sensors. Add water to about 3/4" above the water sensors.

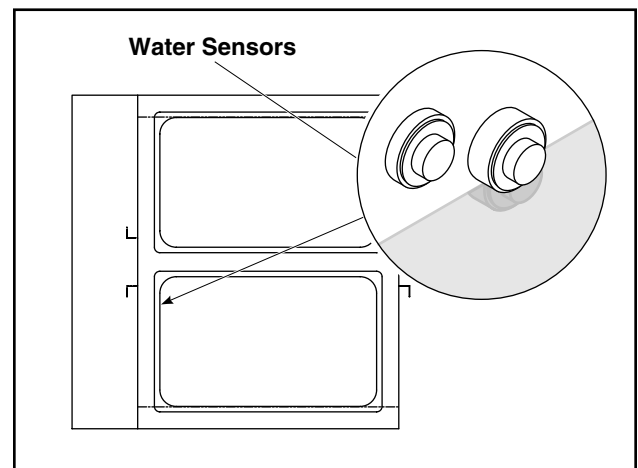



Figure 4: Location of Water Sensors

NOTE: The controller has an OUT light (red lamp). This light blinks as the controller maintains the desired temperature.

Size, weight, pan loading, and product quality will affect cooking times and should be adjusted to fit the requirements of your operation.

Setting Temperature

- To set temperature:

KEY	FUNCTION
Up Key 	Press and release quickly to increase the value of the displayed parameter. Press and hold to accelerate increment speed.
Down Key 	Press and release quickly to decrease the value of the displayed parameter. Press and hold to accelerate decrement speed.

- OUT light will illuminate while cabinet is warming up.
- When OUT light is blinking, the cabinet has reached the desired temperature.

NOTE: The controller is not an indicator of fluid level in the heater or reservoir tank.

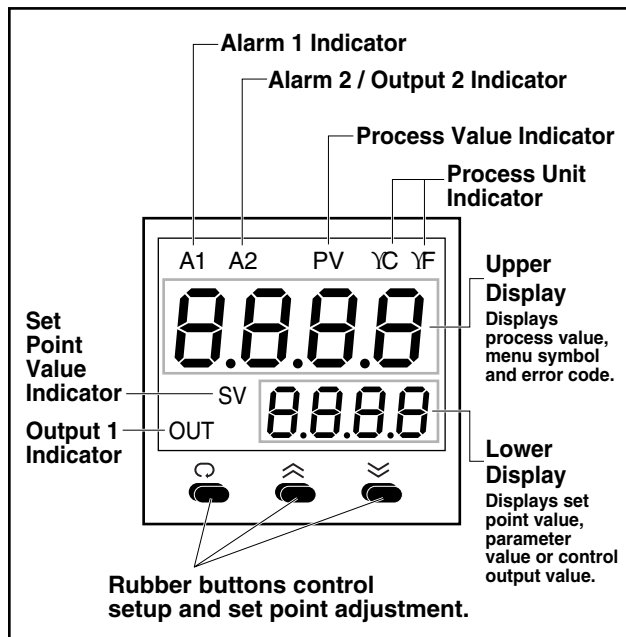

Figure 5: Control Panel Functions

Preheating

Preheat the Thermodyne cabinet when first used for the day or whenever the unit is cold. Preheating takes approximately 30 minutes at which time the temperature set point and the actual temperature will display the same temperature. If the cabinet has door(s), keep the doors closed during the preheat cycle.

FLUID REPLENISHMENT

CAUTION: Use only supplied Thermodyne Heat Transfer Fluid.

WARNING: Disconnect the electrical power to the hot well and perform LOCKOUT/TAGOUT procedure.

WARNING: Drain the hot water for the hot wells before beginning any procedure that requires lifting the hot wells to gain access to the power head.

CAUTION: The cabinet and the hot well may be hot, allow them to cool before beginning this procedure.

- Move the Hot Well power ON/OFF switch to its OFF position. DO NOT turn the oven off.
- Drain all water from the hot wells.

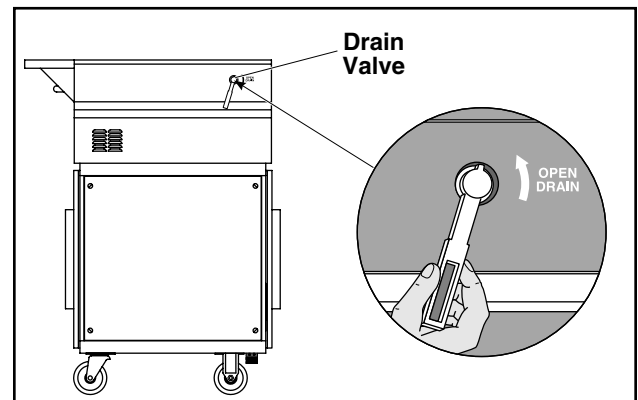

Figure 6: Location of Hot Well Drain Valve

- Using the handle, raise the hot well to gain access to the power head.
- Place the safety catch in its holder.

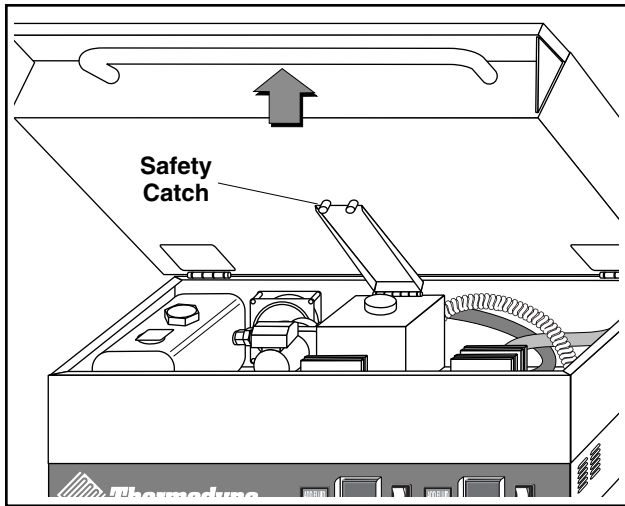

Figure 7: Hot Well in Raised Position

5. Remove the reservoir tank cap.

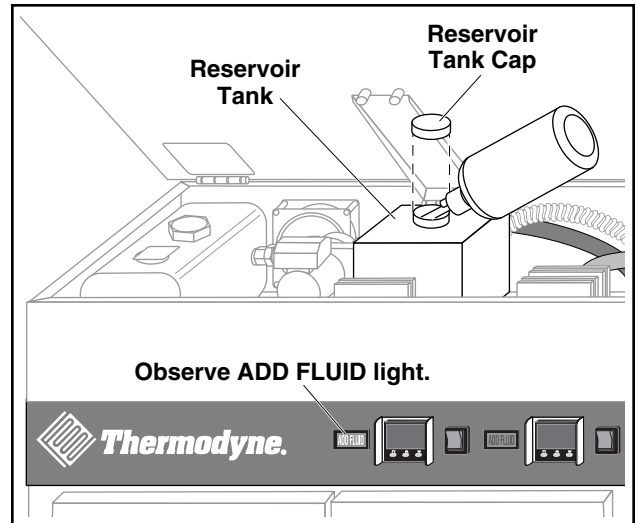

Figure 8: Reservoir Tank Replenishment

6. Fill reservoir tank until oven controller ADD FLUID light turns off.
7. Re-install the reservoir tank cap and fill cap cover.

NOTE: If the ADD FLUID Light remains on after the Thermodyne unit has been filled, refer to TROUBLESHOOTING.

CLEANING AND MAINTENANCE

ELECTRICAL LOCKOUT/TAGOUT PROCEDURE

⚠ WARNING: Before performing any cleaning or maintenance that involves electrical connection or disconnection and/or exposure to electrical components, always follow the Electrical LOCKOUT/TAGOUT Procedure. Disconnect all circuits. Failure to comply can cause property damage, injury or death.

The Electrical LOCKOUT/TAGOUT Procedure is used to protect personnel working on an electrical appliance. Before performing any maintenance or service that requires exposure to electrical components, follow these steps:

1. In electrical box, place appliance circuit breaker into OFF position.
2. Place a lock or other device on electrical box cover to prevent someone from placing circuit breaker ON.
3. Place a tag on electrical box cover to indicate that appliance has been disconnected for service and power should not be restored until tag is removed by maintenance personnel.
4. Disconnect appliance power cord from electrical outlet.
5. Place a tag on the cord to indicate that unit has been disconnected for service and power should not be restored until tag is removed by maintenance personnel.

WHEN TO CLEAN

It is recommended that all stainless steel equipment be cleaned on a regular basis. Any piece of stainless steel equipment that is soiled should be cleaned daily to ensure the long life of the equipment. Routine cleaning will also lessen stainless steel abrasion.

STAINLESS STEEL CARE

Cleaning

Stainless steel contains 70-80% iron, which will rust if not properly maintained. It also contains 12-30% chromium, which forms an invisible passive, protective film that shields against corrosion. If the film remains intact, the stainless steel will remain intact. However, if the film is damaged, the stainless steel can break down and rust. To prevent stainless steel breakdown, follow these steps:

CAUTION: Never use any metal tools. Scrapers, files, wire brushes or scouring pads (except for stainless steel scouring pads) will mar the surface.

CAUTION: Never use steel wool, which will leave behind particles that rust.

CAUTION: Never use acid-based or chloride-containing cleaning solutions, which will break down the protective film.

CAUTION: Never rub in a circular motion.

CAUTION: Never leave any food products or salt on the surface. Many foods are acidic. Salt contains chloride.

For routine cleaning, use warm water, mild soap or detergent and a sponge or soft cloth.

For heavy-duty cleaning, use warm water, a degreaser and a plastic, stainless steel or Scotch-Brite pad.

Always rinse thoroughly. Always rub gently in the direction of the steel grain.

Preserving & Restoring

Special stainless steel polishing cleaners can preserve and restore the protective film.

Preserve the life of stainless steel with a regular application of a high quality stainless steel polishing cleaner as a final step to daily cleaning.

If signs of breakdown appear, restore the stainless steel surface. First, thoroughly clean, rinse and dry the surface. Then, on a daily basis, apply a high-quality stainless steel polish according to manufacturer's instructions.

Heat Tint

Darkened areas, called heat tint, may appear on stainless steel exposed to excessive heat, which causes the protective film to thicken. It is unsightly but is not a sign of permanent damage.

To remove heat tint, follow the routine cleaning procedure. Stubborn heat tint will require heavy-duty cleaning.

To reduce heat tint, limit the exposure of equipment to excessive heat.

CLEANING HEAT TRANSFER PLATES

The Thermodyne unit operates on the principle of conduction, rather than convection. Therefore, it is very important to keep the heat transfer shelves clean, so heat transfer may take place with maximum efficiency. It is also very important to keep the bottom contact surfaces of pots and pans as clean as possible to ensure even and complete heat transfer. The surface and flat coating of the thermal heat transfer shelf is extremely hard, but will react with strong caustic cleaning solutions and deteriorate.

CAUTION: Most concentrated soaps and ammonia cleaners are too caustic to be used on the Thermodyne unit.

If the coating is destroyed, the heat transfer shelves will lose their non-stick properties and their surface hardness.

The cleaners should always be used at the recommended concentrations. In the case of dry powders, the powders must not be placed directly on the surface of the heat transfer plate. Care must be taken not to scratch the shelf surfaces when using brushes or pads. If harsh scouring is needed, use a nylon type scouring pad. NEVER use steel wool.

It is recommended that a weekly cleaning schedule be followed to avoid the buildup of heavy food

product deposits. In the event heavy deposits occur that are difficult to remove with ordinary cleaning procedures, stronger chemical cleaning agents may be applied if the products are intended for food service use and are also compatible with hard coat anodized aluminum surfaces. When using these stronger solvents, it is very important that heat transfer shelves are rinsed thoroughly with clean potable water after cleaning. Be sure to remove all traces of the cleaning agent. Between the regular scheduled cleaning, wipe off the anodized aluminum surfaces periodically with a clean damp cloth.

CLEANING DOOR GASKETS

Clean the gasket-sealing surface of the Thermodyne doors to remove food product acids for maximum gasket life. Do not use any solvents or sharp instruments as these will damage the gasket. Wash with a cloth moistened in a solution of mild detergent and warm water. Rinse with a fresh cloth moistened with warm water to remove all traces of detergent. Wipe dry with a clean cloth. Never apply food product oils or petroleum lubricants directly to the door gasket as these will reduce gasket life.

CHANGING FLUID

NOTICE: The Thermodyne Heat Transfer Fluid has lubricating additives, anticorrosion additives, and heat transfer properties that may decrease with the passing of time. Thermodyne Heat Transfer Fluid will protect the unit indefinitely if the fluid is changed on an annual basis.

CAUTION: The following procedure is to be performed by a qualified service technician only.

⚠ WARNING: Before removing any sheet metal panels or servicing this equipment, always perform the Electrical LOCKOUT/TAGOUT Procedure. Be sure all circuits are disconnected. Failure to comply with this procedure can cause property damage, injury or death.

1. Move Power ON/OFF switches to the OFF position and perform LOCKOUT/TAGOUT procedures.

2. Drain all water from the hot wells.

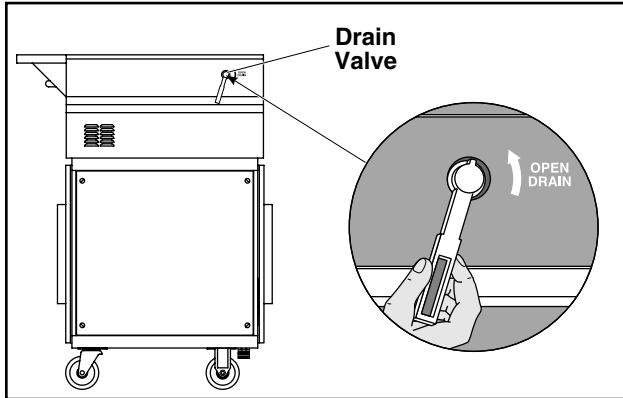

Figure 9: Drain Valve

3. Allow the unit to cool completely.
4. Using the handle, raise the hot well unit to its up position.
5. Place the safety catch in its holder.

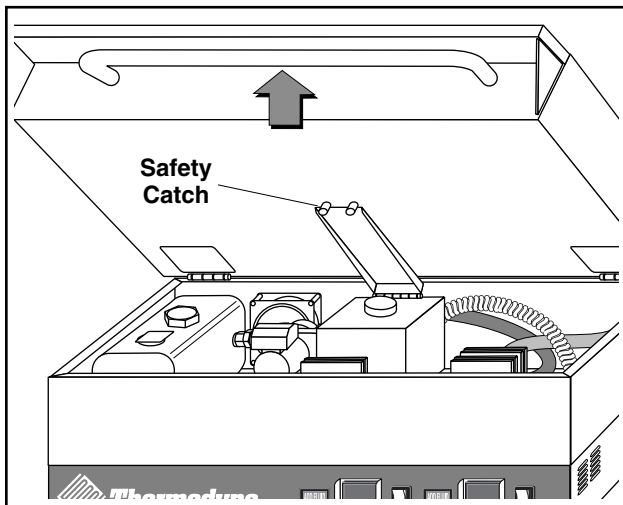

Figure 10: Hot Well in Raised Position

6. Locate heater tank and remove cap.

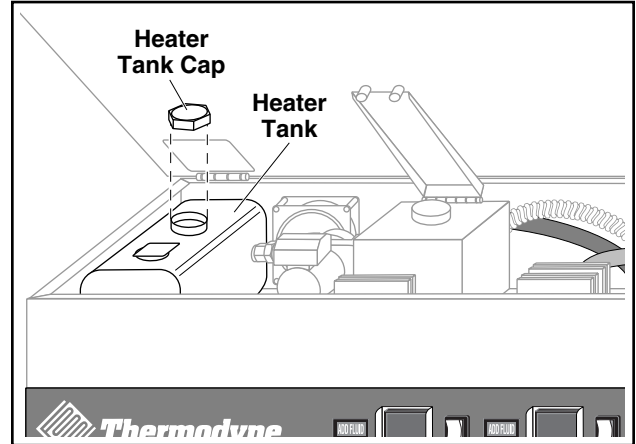

Figure 11: Heater Tank and Cap

7. Remove left side panel to gain access to drain valve.
8. Place a pan or bucket beside drain plug in order to catch drained fluid.

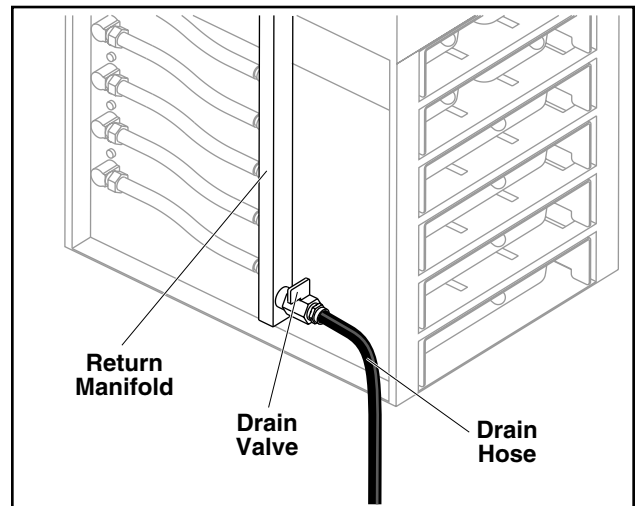

Figure 12: Drain Hose

9. Place drain hose into pan or bucket and turn valve to open position.
10. Once unit has drained completely turn valve to off position and tuck drain hose back into cabinet.
11. Reattach the left side panel.
12. Refill the unit with Thermodyne Heat Transfer Fluid only. Never substitute with water or other liquids.
13. Reattach the heater tank cap.

14. Restore power to the unit and place the Power ON/OFF switch in its ON position.

NOTE: Unit may run briefly and shut off due to low fluid level.

15. Remove reservoir cap and heater tank cap and fill heater tank.

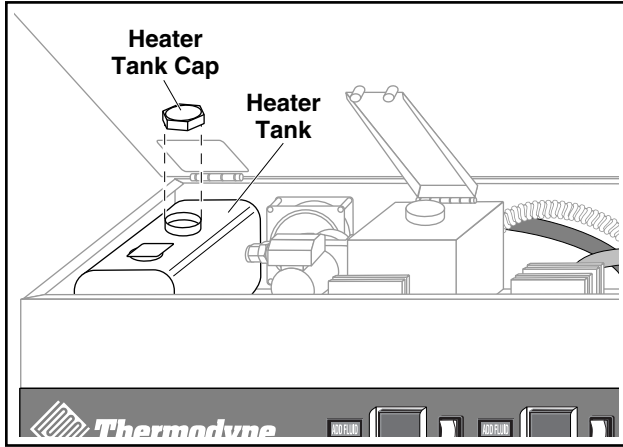

Figure 13: Heater Tank Cap & Reservoir Cap

16. Repeat steps 12-14 until unit is completely full of fluid.

17. Once unit is completely filled, reattach the heater tank cap and the powerhead lid.

NOTE: If ADD FLUID light is on, add fluid to reservoir tank until light goes out.

18. Allow the unit to heat until set temperature is reached.

19. Once set temperature is reached, place the power switch in the OFF position and let the unit cool down to at least 100°F.

20. Turn unit back on, and if ADD FLUID light is on again, add fluid to reservoir tank until light goes out.

NOTE: Steps 18-20 are very critical in order to purge any trapped air from the unit.

TROUBLESHOOTING

Most problems associated with the holding cabinet are due to low fluid level.
Always check fluid level first.

PROBLEM	POSSIBLE CAUSE	SOLUTION
No Power:	<ol style="list-style-type: none"> 1. Main power switch off. 2. Not plugged in. 3. Breaker off or tripped. 4. Bad contactor. 	<ol style="list-style-type: none"> 1. Turn switch on. 2. Check plug. 3. Check breaker. 4. Replace contactor.
LOW FLUID light is on – Oven heating properly:	<ol style="list-style-type: none"> 1. Oven is low on fluid. 	<ol style="list-style-type: none"> 1. Add Thermodyne Heat Transfer Fluid per instructions.
LOW FLUID light is on – Hot Well heating properly.	<ol style="list-style-type: none"> 1. Hot Well is low on water 	<ol style="list-style-type: none"> 1. Add water to 3/4" above water level sensors.
LOW FLUID light is on – Oven not heating properly:	<ol style="list-style-type: none"> 1. Oven disabled due to low fluid level cut out. 2. Fluid level probe defective. 3. System leak. 	<ol style="list-style-type: none"> 1. Main heater tanks low on fluid. Add Thermodyne Heat Transfer Fluid and determine cause of fluid loss. 2. Repair or replace.* 3. Repair leak.*
Heater(s) not working:	<ol style="list-style-type: none"> 1. Unit not properly wired. 2. Bad heater(s). 3. Contactor or solid state relays not working. 4. Off due to low fluid cut out. 5. Failed temperature controller. 6. High limit snap disc tripped. 	<ol style="list-style-type: none"> 1. Check wiring.* 2. Replace heater(s).* 3. Repair or replace.* 4. Add Thermodyne Heat Transfer Fluid per instructions. 5. Replace temperature controller.* 6. Reset snap disc and check for cause.*
Shelves hotter than set point:	<ol style="list-style-type: none"> 1. Temperature controller out of calibration. 2. Thermocouple defective. 3. Solid state relay(s) stuck on. 4. Failed temperature controller. 	<ol style="list-style-type: none"> 1. Recalibrate temperature controller.* 2. Replace thermocouple.* 3. Replace solid state relay(s).* 4. Replace temperature controller.*
Shelves colder than set point:	<ol style="list-style-type: none"> 1. Low fluid in tank. (LOW FLUID light should be lit) 2. Failed temperature controller. 3. Heater(s) not working. 4. Pump failure. 5. Thermocouple failure. 	<ol style="list-style-type: none"> 1. Add Thermodyne Heat Transfer Fluid per instructions. 2. Replace temperature controller.* 3. See “Heater(s) not working”. 4. Repair or replace pump. 5. Replace thermocouple.
Oven heats up too slow:	<ol style="list-style-type: none"> 1. Heater(s) not working. 	<ol style="list-style-type: none"> 1. See “Heater(s) not working”.

*Recommended service to be done by a qualified service agency.

NOTE: Most problems associated with the Thermodyne cabinet are due to failure to add Thermodyne Heat Transfer Fluid. Check fluid level first. In the event service is required on your Thermodyne cabinet, please call: (800) 526-9182.

SCHEMATIC WIRING DIAGRAM

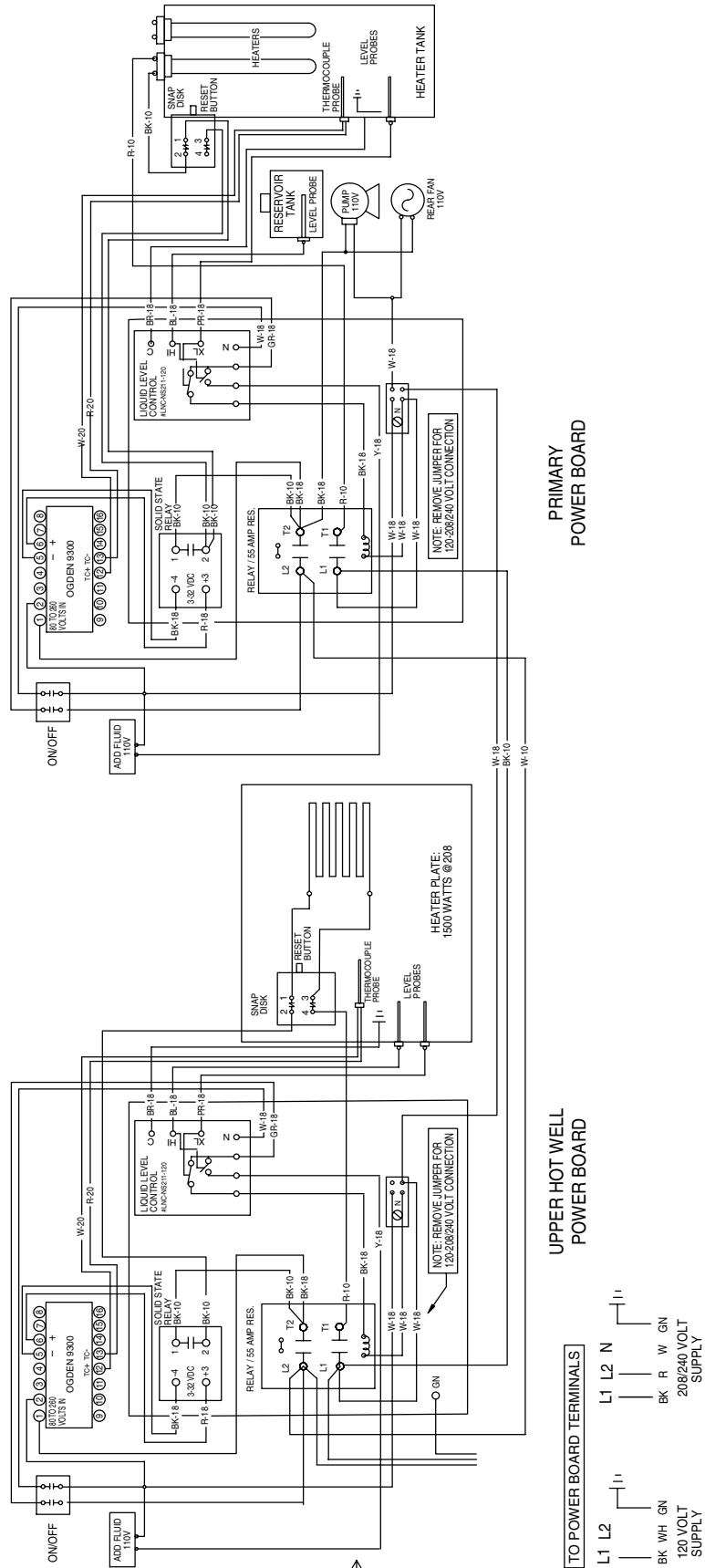

WARRANTY

Thermodyne Foodservice Products, Inc. warrants to the original purchaser for use of each new Thermodyne Conductive Cooking/Holding Oven the following: Any part which proves to be defective in materials or workmanship within the warranty period will, subject to the terms of this warranty, be repaired or replaced at Thermodyne Foodservice, Inc.'s option. Claims under this warranty must be presented to Thermodyne Foodservice Products, Inc. in writing, promptly.

Thermodyne stainless steel cabinets are warranted for 5 years and all other original equipment parts such as heat transfer plates, doors, casters, fluid system components and electrical components are warranted against defect for one year from the date of purchase.

This warranty applies only to Thermodyne Conductive Cooking/Holding Ovens in the Continental United States. This warranty shall not apply if the oven or any part is subjected to accident, casualty, alteration, misuse, abuse, neglect, faulty installation, or if the date of manufacture is altered or removed.

The obligation of Thermodyne Foodservice Products, Inc. is limited specifically to the aforementioned. No additional guarantees or warranty, expressed or implied, to include without limitation warranties of Fitness or Merchantability with respect to Thermodyne Conduction Ovens and Thermodyne Foodservice Products, Inc. regarding other liability with respect thereto including, without limitation, liability for incidental, special, or consequential damages.

RESPONSIBILITIES OF PURCHASER

It is the responsibility of the purchaser to:

1. Arrange on site electrical services in accordance with Thermodyne specifications.
2. Receive shipment of Thermodyne conduction oven to include unloading, uncrating, inspecting for damage in shipment, and installation of the oven in its proper location; in accordance with installation instructions.
3. Arrange that the electric services are connected properly by a qualified technician. All such connections must be in accordance with applicable code requirements and Thermodyne installation procedures.

Please note the specific details on the Warranty and make certain that service connections are made to the proper utility services. This warranty and purchasers responsibility information should be retained for future reference.

For assistance please call:

Toll Free: (800) 526-9182

Local: (260) 428-2535

HEAT TRANSFER FLUID MSDS

Dow Chemical U.S.A.
Midland, MI 48674
Emergency Phone: 517-636-4400
Product Code: 23545
Product Name: PROPYLENE GLYCOL
HEAT TRANSFER FLUID
Effective Date: 03-02-88
Date Printed: 06/02/88
MSDS: 000130

1. **INGREDIENTS:**
Propylene glycol CAS# 000057-55-6 95%
Dipotassium phosphate CAS# 007758-11-4 <5%
Deionized water CAS# 007732-18-5 <5%

This document is prepared pursuant to the OSHA Hazard Communication Standard (29CFR 1910.1200). In addition, other substances not 'Hazardous' per this OSHA Standard may be listed. Where proprietary ingredient shows, the identity may be made available as provided in this standard.

2. **PHYSICAL DATA:**
BOILING POINT: 370F, 188C
VAP. PRESS: 0.22 mmHg @ 20C, 68F
VAP. DENSITY: 2.62
SOL. IN WATER; Complete
SP. Gravity: 1.050 @ 60/60F, 16C
APPEARANCE: Colorless.
ODOR: Odorless liquid.

3. **FIRE AND EXPLOSION HAZARD DATA:**
FLASH POINT: 215F, 102C
METHOD USED: COC
FLAMMABLE LIMITS
LFL: 2.6% @ 100C
UFL: 12.5% @ 130C
EXTINGUISHING MEDIA: Water fog, alcohol foam, dry chemical
FIRE AND EXPLOSION HAZARDS: None.
FIRE-FIGHTING EQUIPMENT: None.

4. **REACTIVITY DATA:**
STABILITY: (CONDITIONS TO AVOID)
Stable over normal
Operating temperature range of -30F to 250F.

INCOMPATIBILITY: (SPECIFIC MATERIALS TO AVOID)
Oxidizing material.
HAZARDOUS DECOMPOSITION PRODUCTS: None
HAZARDOUS POLYMERIZATION: Will not occur.

5. **ENVIRONMENTAL AND DISPOSAL INFORMATION:**
ACTION TO TAKE FOR SPILLS/LEAKS:
Cover with absorbent material, soak up and sweep into bag.

6. **HEALTH HAZARD DATA:**
EYE: May cause slight transient eye irritation. Corneal injury is unlikely.
SKIN CONTACT: Essentially nonirritating to skin on prolonged contact.
SKIN ABSORPTION: A single prolonged skin exposure is not likely to result in

absorption of harmful amounts. The LD50 for skin absorption in rabbits is >10,000 mg/kg.

Repeated exposures may cause slight flaking, tenderness and softening of skin.

INGESTION: Single does oral toxicity is low. The LD50 for female rats is about 20.3 g/kg

INHALATION: A single prolonged (hours) inhalation exposure is not likely to cause adverse side effects. Mists are not to be hazardous.

SYSTEMIC & OTHER EFFECTS: Repeated excessive ingestion may cause central nervous system effects. No carcinogenic effects have been seen in long-term animal studies. Birth defects are unlikely. Exposures having no adverse effects on the mother should have no effect on the fetus. In animal studies, has been shown not to interfere with reproduction. Results of mutagenicity tests in vitro (test tube) and in animals have been negative.

7. **FIRST AID**
EYES: Irrigate immediately with water for at least 5 minutes.

SKIN: wash off in flowing water or shower

INGESTION: Induce vomiting if large amounts are ingested, consult medical

INHALATION: Remove to fresh air if effects occur. Consult medical.
NOTE TO PHYSICIAN: No specific antidote. Supportive care. Treatment based on judgment of the physician in response to reactions of the patient.

8. **HANDLING PRECAUTIONS:**
EXPOSURE GUIDELINE (S): Dow IHG is 10mg/m3 for propylene glycol mist. Dow IHG 440 ppm for propylene glycol vapors.

VENTILATION: Good general ventilation sufficient.

RESPIRATORY PROTECTION: No respiratory protection should be needed.

SKIN PROTECTION: No precautions other than clean body covering should be needed.

EYE PROTECTION: Use safety glasses.

9. **ADDITIONAL INFORMATION:**
REGULATORY REQUIREMENTS:

SARAHAZARDCATEGORY: This product has been reviewed according to the EPA 'Hazard Categories' promulgated under Section 311 and 312 of the Superfund Amendment and Reauthorization Act of 1986 (SARA Title III) and is considered, under applicable definitions, to meet the following categories: A delayed hazard.
SPECIAL PRECAUTIONS TO BE TAKEN IN HANDLING AND STORAGE: Exercise reasonable care and caution.

MSDS STATUS: Revised Section 9

NOTES

