

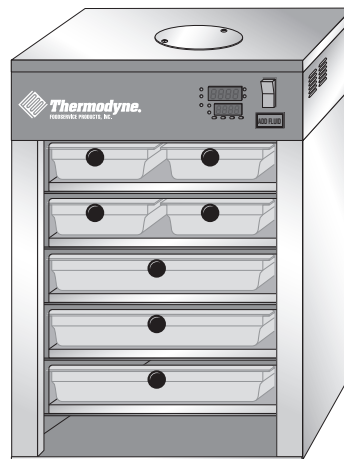

SERVICE MANUAL

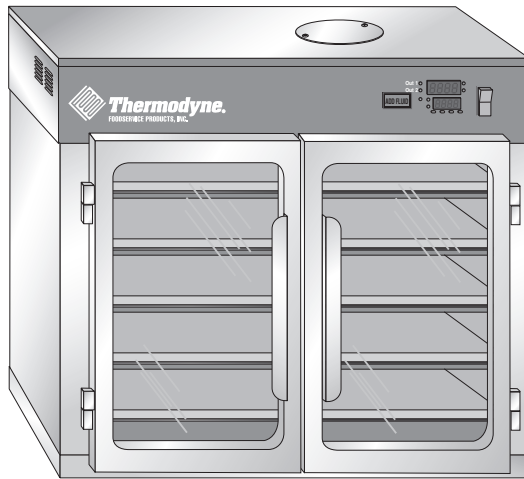

MODELS

200 NDNL
200 CT
250 PNDDT
300 NDNL
300 CT

300 OC
700 NDNL
700 CT
725 NDNL

950 NDNL
957 NDNL
1600 NDNL
BW3S NDNL

For additional information on Thermodyne Foodservice Products, Inc.,
or to locate an authorized parts and service provider in your area,
visit our website at www.tdyne.com.

Please visit our website to Register your Thermodyne unit. Registration ensures that you
get up-to-date warranty and product information, along with fast and convenient service.

<http://www.tdyne.com/register.aspx>

Thermodyne Foodservice Products, Inc.
4418 New Haven Avenue
Fort Wayne, IN 46803

1-800-526-9182
www.tdyne.com

ELECTRICAL WARNINGS

THIS MANUAL HAS BEEN PREPARED FOR PERSONNEL QUALIFIED TO INSTALL ELECTRICAL EQUIPMENT, WHO SHOULD PERFORM THE INITIAL FIELD STARTUP AND ADJUSTMENTS OF THE EQUIPMENT COVERED BY THIS MANUAL.

READ THIS MANUAL THOROUGHLY BEFORE OPERATING, INSTALLING OR PERFORMING MAINTENANCE ON THE EQUIPMENT.



WARNING: Failure to follow all the instructions in this manual can cause property damage, injury or death.



WARNING: Improper installation, adjustment, alteration, service or maintenance can cause property damage, injury or death.



WARNING: Electrical connections should be performed only by a certified professional.



WARNING: Electrical and grounding connections must comply with the applicable portions of the National Electric Code and/or all local electric codes. Failure to comply with this procedure can cause property damage, injury or death.



WARNING: Before connecting the unit to the electrical supply, verify that the electrical and grounding connections comply with the applicable portions of the National Electric Code and/or other local electrical codes. Failure to comply with this procedure can cause property damage, injury or death.



WARNING: Before connecting the unit to the electrical supply, verify that the electrical connection agrees with the specifications on the data plate. Failure to comply with this procedure can cause property damage, injury or death.



WARNING: UL73 grounding instructions: This appliance must be connected to a grounded, metal, permanent wiring system. Or an equipment-grounding conductor must be run with the circuit conductors and connected to the equipment-grounding terminal or lead on the appliance. Failure to comply with this procedure can cause property damage, injury or death.



WARNING: Appliances equipped with a flexible electric supply cord, are provided with a three-prong grounding plug. It is imperative that this plug be connected into a properly grounded three-prong receptacle. Failure to comply with this procedure can cause property damage, injury or death.



WARNING: If the receptacle is not the proper grounding type, contact an electrician. Do not remove the grounding prong from the plug. Failure to comply with this procedure can cause property damage, injury or death.



WARNING: Before performing any service that involves electrical connection or disconnection and/or exposure to electrical components, always perform the Electrical LOCKOUT/TAGOUT Procedure. Disconnect all circuits. Failure to comply with this procedure can cause property damage, injury or death.



WARNING: Before removing any sheet metal panels, always perform the Electrical LOCKOUT/TAGOUT Procedure. Be sure all circuits are disconnected. Failure to comply with this procedure can cause property damage, injury or death.



WARNING: Do not operate this equipment without properly placing and securing all covers and access panels. Failure to comply with this procedure can cause property damage, injury or death.



WARNING: Do not use or store gasoline or other flammable vapors or liquids in the vicinity of this or any other appliance. Failure to comply can cause property damage, injury or death.



WARNING: In the event of a power failure, do not attempt to operate this appliance. Failure to comply can cause property damage, injury or death.

TABLE OF CONTENTS

ELECTRICAL WARNINGS	2
ELECTRICAL LOCKOUT/TAGOUT PROCEDURE	5
COVERS AND PANELS	6
Top Fill Cover	6
Power Head Lid.....	6
Units with Doors	6
COMPONENT LOCATOR.....	7
Power Head Components	7
Delivery Manifold Components	8
Return Manifold Components	9
COMPONENT REMOVAL AND REPLACEMENT.....	10
Electrical Components	10
Power Toggle Switch	10
Add Fluid Light	11
Temperature Controller.....	11
Cooling Fan.....	12
Power Cord	13
POWER BOARD COMPONENTS.....	13
Solid State Relay	13
120VAC Float Board.....	14
300NDNL TWELVE BUTTON TIMER.....	15
PLUMBING COMPONENTS	16
B&G Pump	16
Teflon Hoses	17
Fluid Level Probes.....	18
Snap Disc.....	20
Thermocouple	20
Heat Elements	22
MAINTENANCE PROCEDURES	24
Temperature Controller Set Up Procedures.....	24
Keypad Operation	24
Unlock the Controller.....	24
Set-Up.....	24
To Toggle Between °F and °C Readout.....	24
Changing the Heat Transfer Fluid.....	25
CT Door Adjustment.....	25
Stainless Steel Care.....	26
TROUBLESHOOTING.....	27
WIRING SCHEMATIC	28
FLUID CAPACITIES (STANDARD SHELF CONFIGURATION).....	31
WARRANTY	32
HEAT TRANSFER FLUID MSDS	32

ELECTRICAL LOCKOUT/TAGOUT PROCEDURE



WARNING: Before performing any service that involves electrical connection or disconnection and/or exposure to electrical components, always follow the Electrical LOCKOUT/TAGOUT Procedure. Disconnect all circuits. Failure to comply can cause property damage, injury or death.

The Electrical LOCKOUT/TAGOUT Procedure is used to protect personnel working on an electrical appliance. Before performing any maintenance or service that requires exposure to electrical components, follow these steps:

1. In electrical box, place appliance circuit breaker into OFF position.
2. Place a lock or other device on electrical box cover to prevent someone from placing circuit breaker ON.
3. Place a tag on electrical box cover to indicate that appliance has been disconnected for service and power should not be restored until tag is removed by maintenance personnel.
4. Disconnect appliance power cord from electrical outlet.
5. Place a tag on the cord to indicate that unit has been disconnected for service and power should not be restored until tag is removed by maintenance personnel.

COVERS AND PANELS

TOP FILL COVER

The Top Fill Cover provides access to the Reservoir Tank Cap without the requirement to remove the entire Power Head Lid. Remove the cover to access the Reservoir Tank Cap when the Add Fluid Light is illuminated.

1. Place the Power Switch in its OFF position.
2. Remove the Philips screws securing the Top Fill Cover.
3. Remove the Top Fill Cover.

POWER HEAD LID



WARNING

Before removing any sheet metal panels, always perform the Electrical LOCKOUT/TAGOUT Procedure. Be sure all circuits are disconnected. Failure to comply with this procedure can cause property damage, injury or death.

Under normal circumstances it is not necessary to remove the Back Panel to access components. The exception to this is the BW3SNDNL model. The Back Panel on the BW3SNDNL provides access to the Heater Tank components and the Pump.

The Back Panel on the 950NDNL and 957NDNL may be lifted off to provide pass through access.

1. Follow the LOCKOUT/TAGOUT procedure.
2. Remove the Philips screws securing the Back Panel.
3. Lift the Back Panel up and away from the unit.

UNITS WITH DOORS

All CT models are supplied with doors. The doors are provided with lift off hinges. To remove the doors, open the slightly and lift it straight up and off the hinge.

COMPONENT LOCATOR

POWER HEAD COMPONENTS

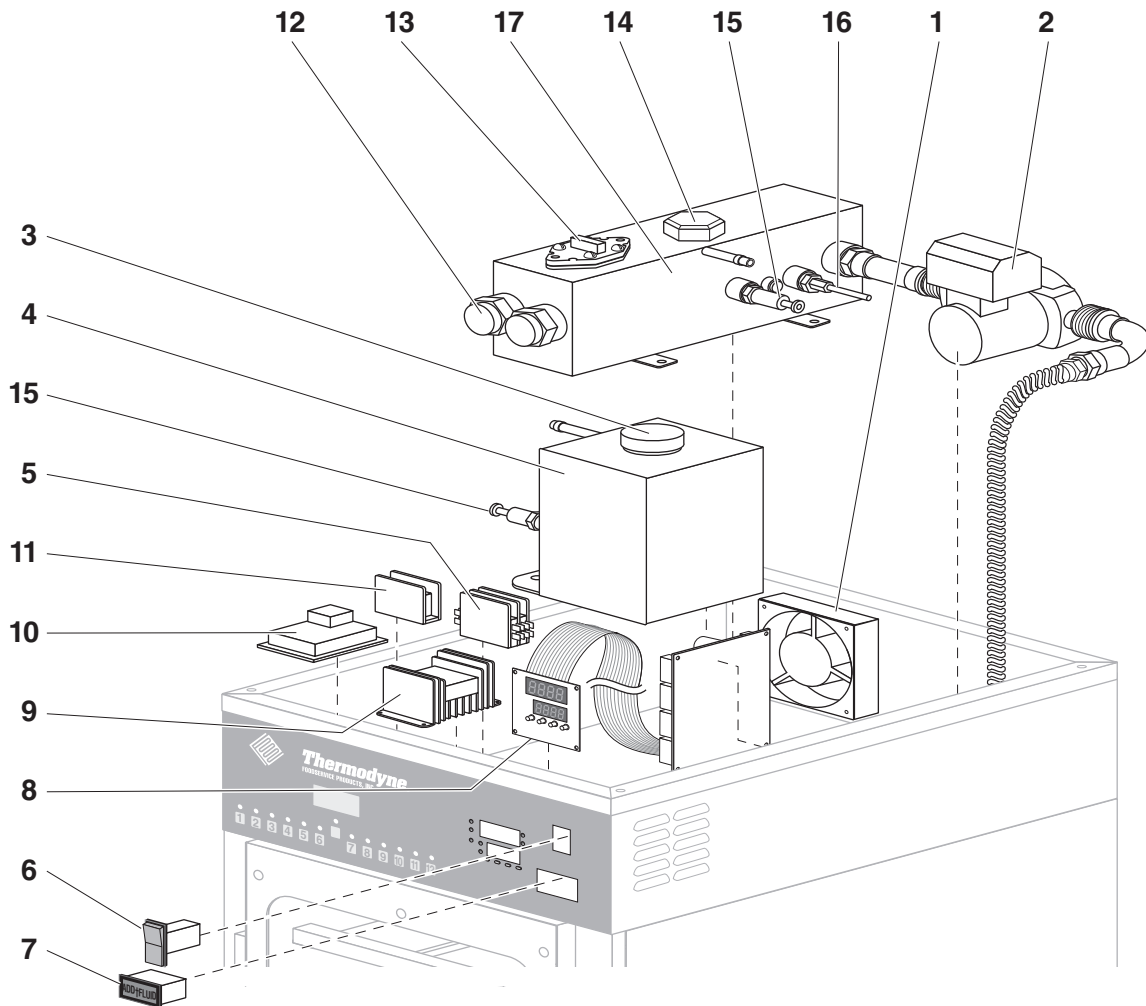

Figure 1: Power Head Components

- | | |
|--------------------------------|--------------------------|
| 1. Cooling Fan | 10. 120VAC Float Board |
| 2. B&G Pump | 11. Neutral Lug |
| 3. Reservoir Fill Cap | 12. Heater Elements |
| 4. Reservoir Assembly | 13. Snap Disc |
| 5. Contactor | 14. 16 PSI Pressure Cap |
| 6. Lighted Power Toggle Switch | 15. Fluid Level Probes |
| 7. Add Fluid Light | 16. Thermocouple |
| 8. Temperature Controller | 17. Heater Tank Assembly |
| 9. Solid State Relay | |

DELIVERY MANIFOLD COMPONENTS

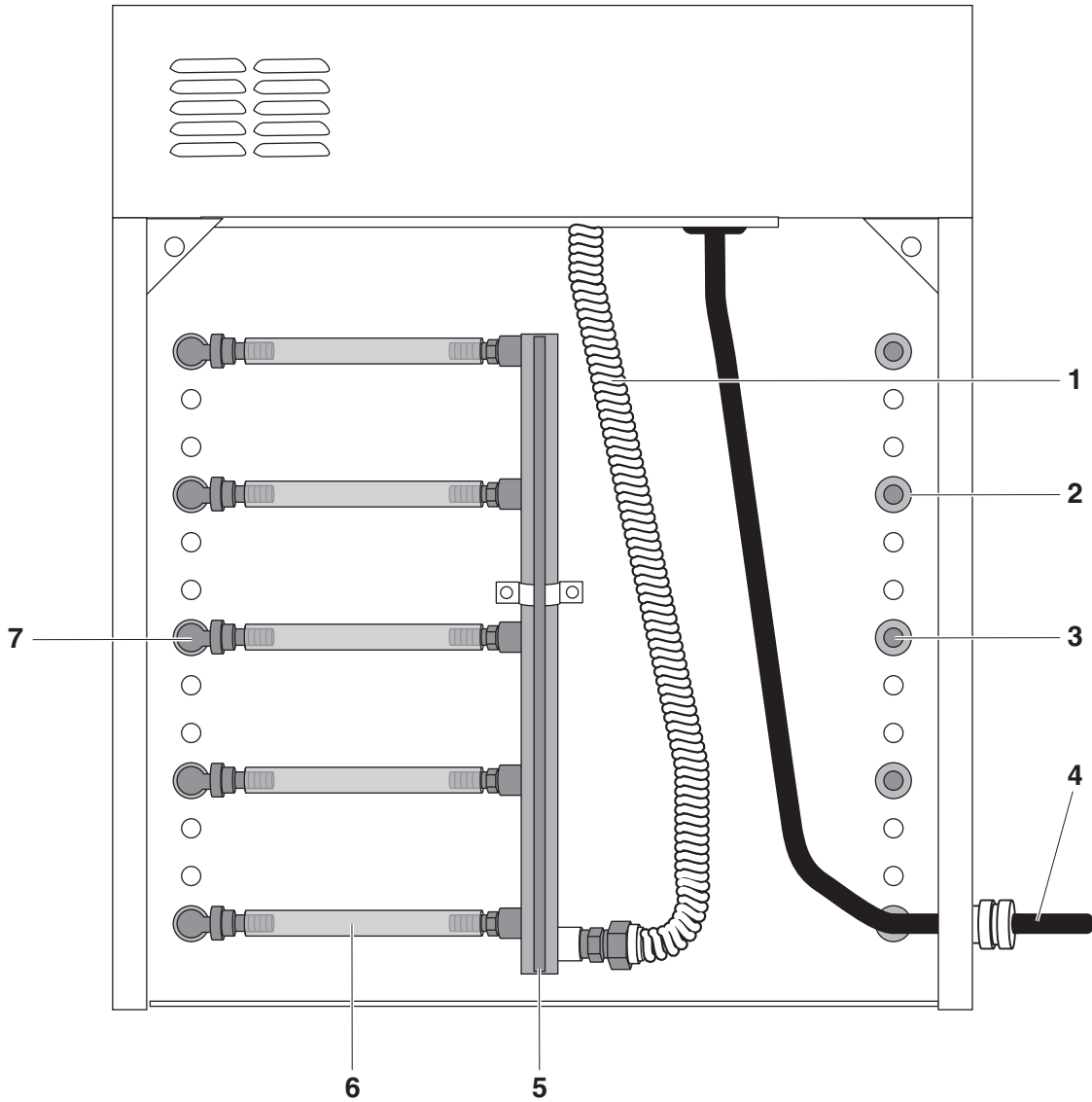

Figure 2: Delivery Manifold Components

1. Delivery Line
2. Teflon Washer
3. Shelf Plug
4. Power Cord
5. Delivery Manifold Assembly
6. Short Teflon Hose
7. Shelf Elbow

RETURN MANIFOLD COMPONENTS

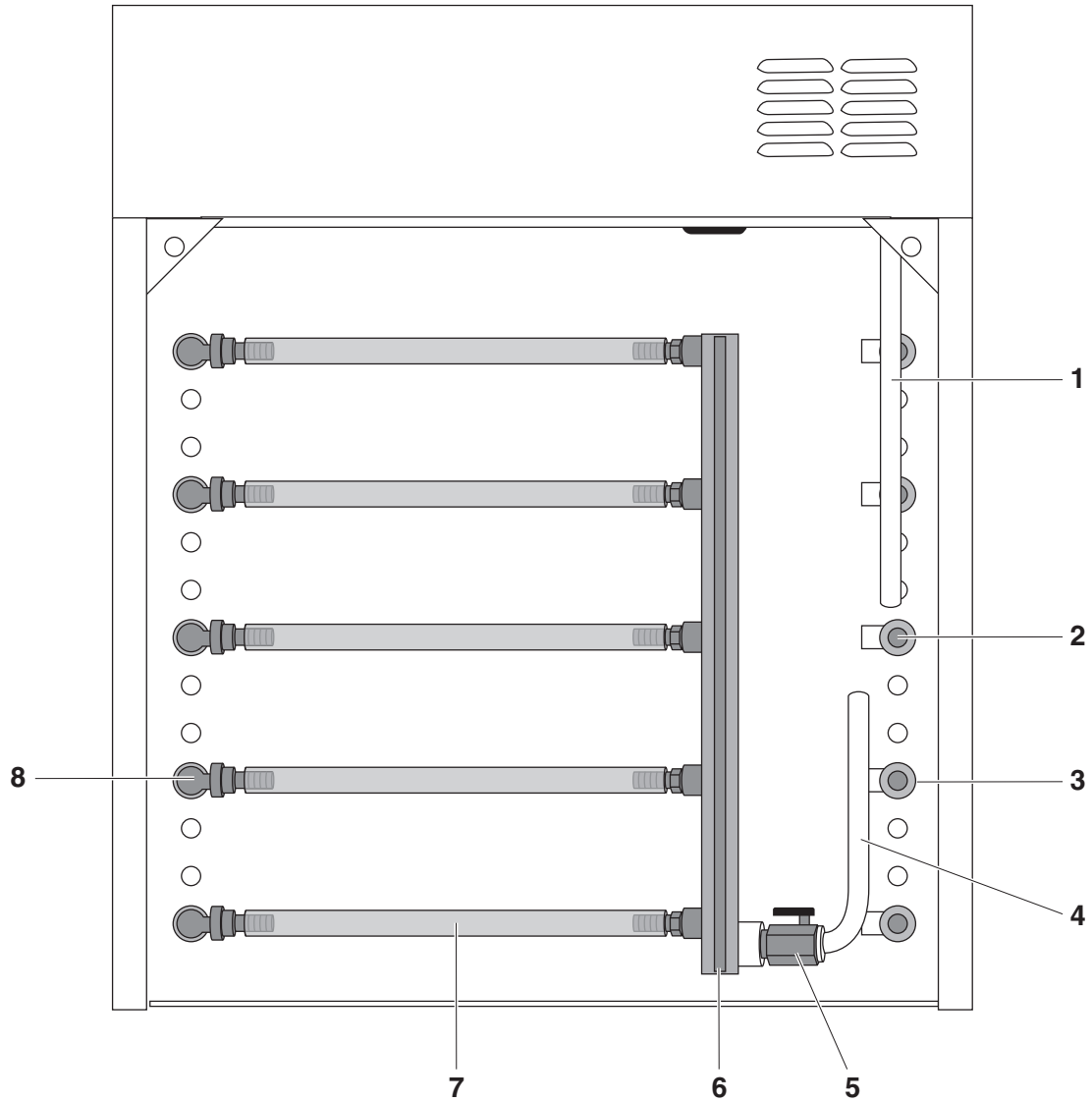

Figure 3: Return Manifold Components

1. Overflow Tube
2. Shelf Plug
3. Teflon Washer
4. Drain Tube
5. Drain Tube ON/OFF Valve
6. Return Manifold
7. Long Teflon Hose
8. Shelf Elbow

COMPONENT REMOVAL AND REPLACEMENT

ELECTRICAL COMPONENTS



WARNING

Before removing any sheet metal panels or servicing this equipment, always perform the Electrical LOCKOUT/TAGOUT Procedure. Be sure all circuits are disconnected. Failure to comply with this procedure can cause property damage, injury or death.



WARNING

Certain components may be hot if the unit was in operation prior to performing a procedure. Allow the unit to cool before beginning work.

POWER TOGGLE SWITCH

1. Follow the LOCKOUT/TAGOUT procedure using the procedures provided in the **Lockout/Tagout Procedures** section of this manual.
2. Remove the Power Head Lid following the instructions provided in the **Panels and Covers** section of this manual.
3. Tag and disconnect the wires connected to the Power Toggle Switch
4. Squeeze the spring tabs that hold the switch in place and push the switch through the front of the unit.

NOTE: If the switch being removed is damaged, it may be easier to break the spring tabs off of the switch rather than attempting to squeeze the spring tabs. If this method is used, remember to remove the broken tabs from the inside of the Power Head.

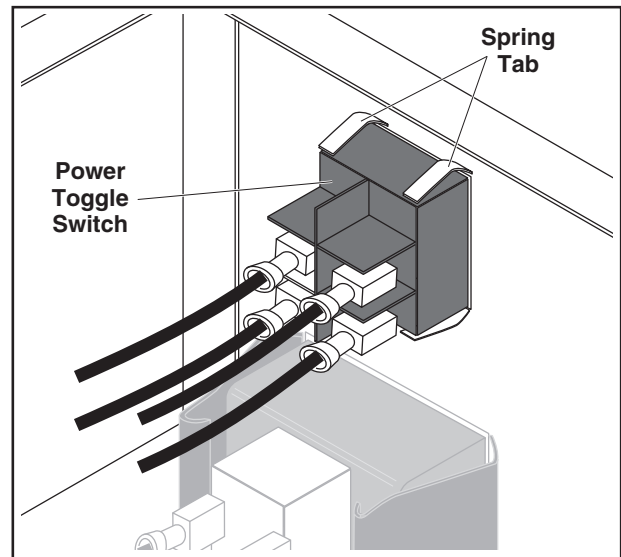

Figure 4: Power Toggle Switch

5. Insert the new switch through the front of the unit ensuring the tabs have locked in place.
6. Referring to the tags or Circuit Schematic reconnect all of the wires.
7. Restore power to the unit and check the switch for proper operation.
8. Remove the units from power.
9. Replace the Power Head Lid.
10. Restore power to the unit and verify proper operation.



WARNING

Before removing any sheet metal panels or servicing this equipment, always perform the Electrical LOCKOUT/TAGOUT Procedure. Be sure all circuits are disconnected. Failure to comply with this procedure can cause property damage, injury or death.



WARNING

Certain components may be hot if the unit was in operation prior to performing a procedure. Allow the unit to cool before beginning work.

ADD FLUID LIGHT

1. Follow the LOCKOUT/TAGOUT procedure using the procedures provided in the **Lockout/Tagout Procedures** section of this manual.
2. Remove the Power Head Lid following the instructions provided in the **Panels and Covers** section of this manual.
3. Tag and disconnect the wires connected to the Add Fluid Light. For easier access to the Add Fluid Light, tag and disconnect the Power Toggle Switch wires.
4. Squeeze the spring tabs that hold the Add Fluid Light in place and push it through the front of the unit.

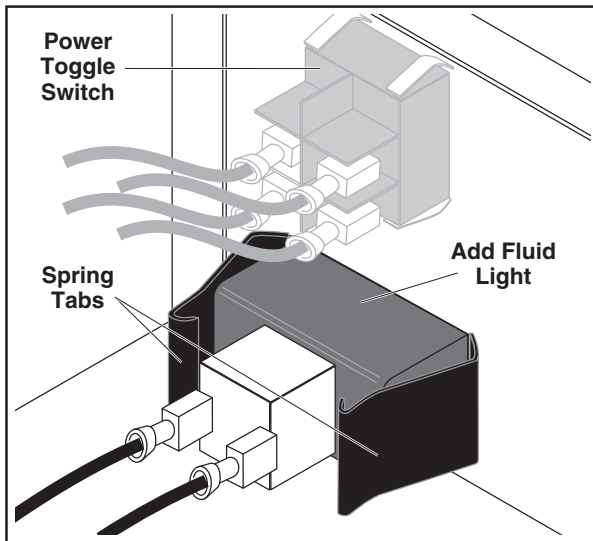

Figure 5: Add Fluid Light

5. Insert the new Add Fluid Light through the front of the unit ensuring the tabs have locked in place.
6. Referring to the tags or Circuit Schematic reconnect the wires.
7. Restore power to the unit and check the Add Fluid Light for proper operation.

NOTE: The Add Fluid Light will not illuminate if the Heat Transfer Fluid level is sufficient. Drain fluid as necessary in order to test for proper light operation. Refer to the **Changing the Heat Transfer Fluid** section of this manual for procedures on draining and adding Heat Transfer Fluid.

8. Remove the units from power.
9. Replace the Power Head Lid.
10. Restore power to the unit and verify proper operation.



WARNING

Before removing any sheet metal panels or servicing this equipment, always perform the Electrical LOCKOUT/TAGOUT Procedure. Be sure all circuits are disconnected. Failure to comply with this procedure can cause property damage, injury or death.



WARNING

Certain components may be hot if the unit was in operation prior to performing a procedure. Allow the unit to cool before beginning work.

TEMPERATURE CONTROLLER

The Temperature Controller consists of two parts: the Controller Main Board (wire harness terminals) and the Display/Pushbutton Board. These two boards are connected by a multi-conductor ribbon cable.

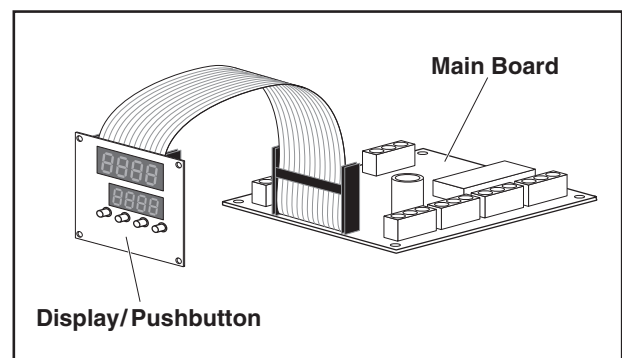

Figure 6: Temperature Controller

1. Follow the LOCKOUT/TAGOUT procedure using the procedures provided in the **Lockout/Tagout Procedures** section of this manual.
2. Remove the Power Head Lid following the instructions provided in the **Panels and Covers** section of this manual.
3. The TBC-41 Controller is very easy to remove.

There are four screws and spacers apiece holding the display and power boards. They are different lengths: the spacers used with the power board are 1/2" (12.7mm) long; the spacers used with the display board are 5/16" (8mm) long.

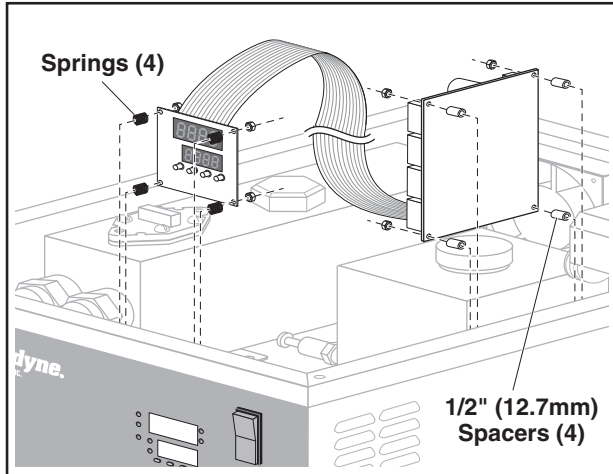

Figure 7: Temperature Controller Removal

4. Restore the power and check the controller for proper operation.
5. Remove the unit from its power source and reattach the Power Head Lid.
6. Restore power to the unit and ensure it is operating correctly.

NOTICE: The new Temperature Controller may require set up procedures. Refer to the **Temperature Controller Set Up Procedures** section of this manual for set up procedures.

 **WARNING**

Before removing any sheet metal panels or servicing this equipment, always perform the **Electrical LOCKOUT/TAGOUT Procedure**. Be sure all circuits are disconnected. Failure to comply with this procedure can cause property damage, injury or death.

 **WARNING**

Certain components may be hot if the unit was in operation prior to performing a procedure. Allow the unit to cool before beginning work.

COOLING FAN

1. Follow the **LOCKOUT/TAGOUT** procedure using the procedures provided in the **Lockout/Tagout Procedures** section of this manual.
2. Remove the Power Head Lid following the instructions provided in the **Panels and Covers** section of this manual.
3. Unplug the leads from the fan.
4. Remove the four screws securing the fan to the Power Head.

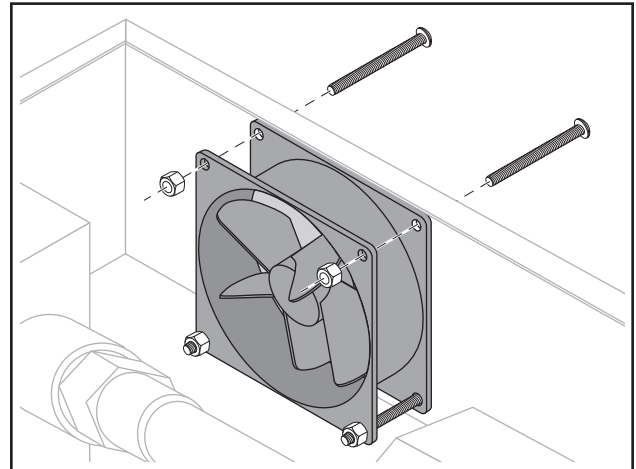

Figure 8: Cooling Fan

5. Reverse this procedure to install the new Cooling Fan.

 **WARNING**

Before removing any sheet metal panels or servicing this equipment, always perform the **Electrical LOCKOUT/TAGOUT Procedure**. Be sure all circuits are disconnected. Failure to comply with this procedure can cause property damage, injury or death.

 **WARNING**

Certain components may be hot if the unit was in operation prior to performing a procedure. Allow the unit to cool before beginning work.

POWER CORD

1. Follow the LOCKOUT/TAGOUT procedure using the procedures provided in the **Lockout/Tagout Procedures** section of this manual.
2. Remove the Power Head Lid following the instructions provided in the **Panels and Covers** section of this manual.
3. Disconnect the Power Cord from the Contactor and remove the ground screw securing the green ground wire to the unit's chaise.
4. Refer to the unit's schematic, connect the new power cord.
5. Restore power to the unit.
6. Verify unit is working properly.
7. Remove the unit from its power supply.
8. Reattach the Power Head Lid
9. Restore power to the unit and ensure unit is operating correctly.

POWER BOARD COMPONENTS

The Power Board Components include the Solid State Relay, Contactor, 120VAC Float Board and the Neutral Lug. Under normal circumstances it should not be necessary to replace either the Contactor or Neutral Lug.

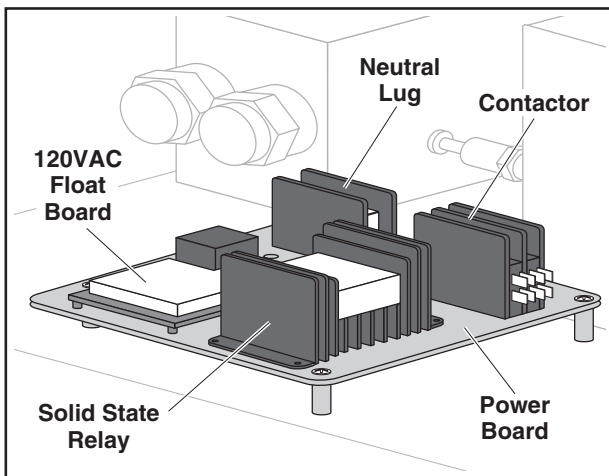

Figure 9: Power Board Component Locator

NOTICE: The Power Board is mounted on plastic risers that allow for air flow on the underside of

the board. It is not necessary to remove the board when replacing one of its components; however it may be necessary to loosen the screws that secure the Power Board to the unit. Loosen the screws but do not remove them as they will hold the plastic risers in place.



WARNING
Before removing any sheet metal panels or servicing this equipment, always perform the Electrical LOCKOUT/TAGOUT Procedure. Be sure all circuits are disconnected. Failure to comply with this procedure can cause property damage, injury or death.



WARNING
Certain components may be hot if the unit was in operation prior to performing a procedure. Allow the unit to cool before beginning work.

Solid State Relay

1. Follow the LOCKOUT/TAGOUT procedure using the procedures provided in the **Lockout/Tagout Procedures** section of this manual.
2. Remove the Power Head Lid following the instructions provided in the **Panels and Covers** section of this manual.
3. Tag and disconnect the wires mounted to the Solid State Relay.
4. Remove the Solid State Relay by removing the four screws securing it to the Power Board. It may be necessary to loosen screws securing the Power Board to gain access to the screws at the front of the relay.

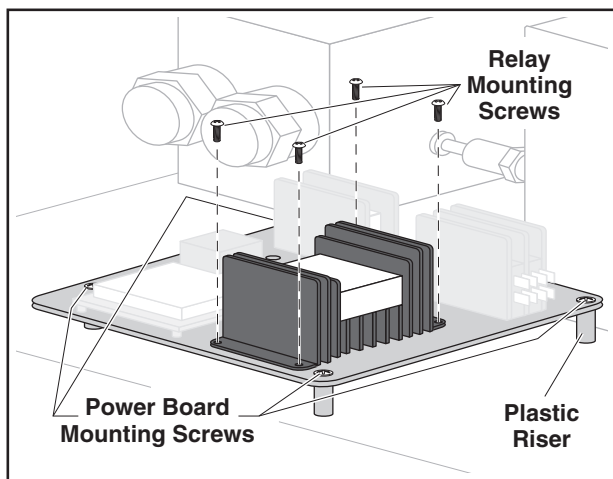

Figure 10: Solid State Relay

5. Install the new Solid State Relay.
6. Reattach the screws securing the Power Board to the unit
7. Referring to the tags or to the wiring schematic reconnect the wires to the new relay.
8. Restore power to the unit and verify operation.
9. Remove the unit from its power source and reattach the Power Head Lid
10. Restore power to the unit and check it for proper operation.



WARNING

Before removing any sheet metal panels or servicing this equipment, always perform the Electrical LOCKOUT/TAGOUT Procedure. Be sure all circuits are disconnected. Failure to comply with this procedure can cause property damage, injury or death.



WARNING

Certain components may be hot if the unit was in operation prior to performing a procedure. Allow the unit to cool before beginning work.

120VAC Float Board

1. Follow the LOCKOUT/TAGOUT procedure using the procedures provided in the **Lockout/Tagout Procedures** section of this manual.
2. Remove the Power Head Lid following the instructions provided in the **Panels and Covers** section of this manual.
3. Tag and disconnect the wires attached to the 120VAC Float Board.
4. Remove the screws and plastic risers securing the float board to the Power Board and lift the float board out of the unit.

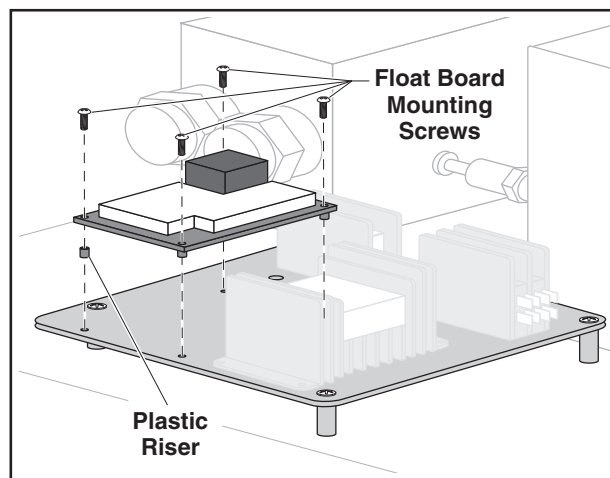

Figure 11: 120VAC Float Board

NOTE: It is NOT necessary to loosen the Power Board screws to gain access to the float board

5. Install the new float board making sure a plastic riser is attached it each screw.
6. Referring to the tags or the wiring schematic reconnect the wires to the float board.
7. Restore power to the unit and check it for proper operation.
8. Remove the units from its power source and reattach the Power Head Lid.
9. Restore power to the units and verify its operation.



WARNING

Before removing any sheet metal panels or servicing this equipment, always perform the Electrical LOCKOUT/TAGOUT Procedure. Be sure all circuits are disconnected. Failure to comply with this procedure can cause property damage, injury or death.



WARNING

Certain components may be hot if the unit was in operation prior to performing a procedure. Allow the unit to cool before beginning work.

300NDNL TWELVE BUTTON TIMER

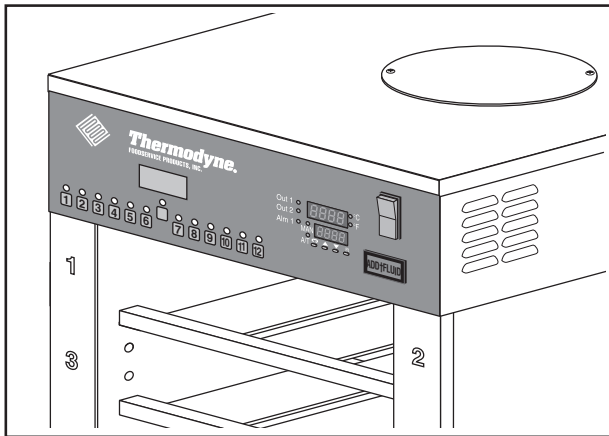

Figure 12: 300NDNL Twelve Button Timer

1. Follow the LOCKOUT/TAGOUT procedure using the procedures provided in the **Lockout/Tagout Procedures** section of this manual.
2. Remove the Power Head Lid following the instructions provided in the **Panels and Covers** section of this manual.
3. Tag and disconnect all of the component wires on the Power Board.
4. Remove the screws and plastic risers that secure the power board to the unit and lift the board and its components out of the unit.

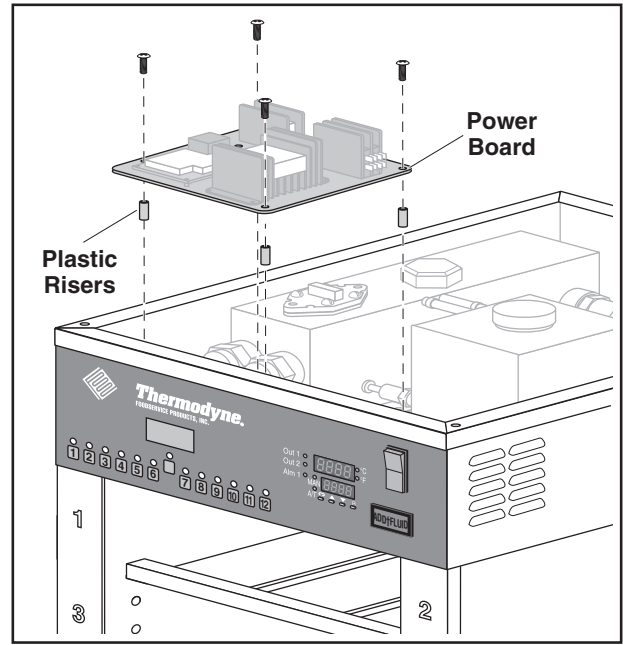

Figure 13: Power Board and Components

5. Tag and disconnect the wires attached to the Twelve Button Timer.
6. Remove the screws securing the timer to the unit.

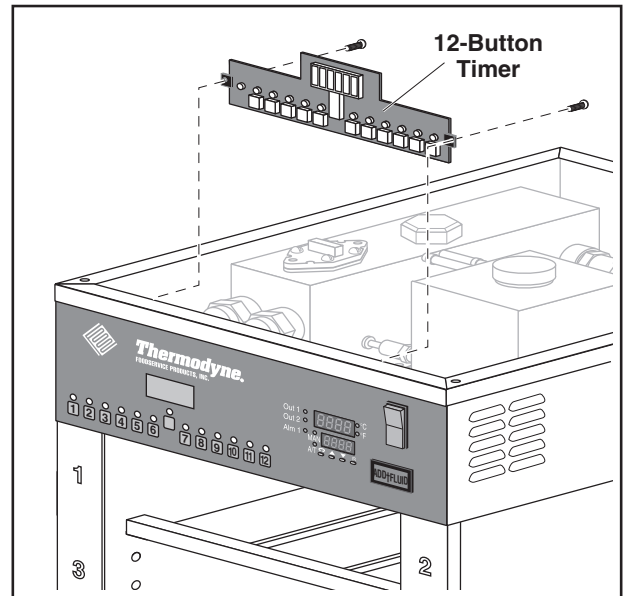

Figure 14: Twelve Button Timer with Power Board Removed

7. Replace the timer and reattach its wires
8. Reinstall the Power Board, make sure each screw has its plastic riser installed.

9. Referring to the tags or the wiring schematic reattach the Power Board component's wiring.
10. Restore power to the unit and check the timer for proper operation.
11. Remove the unit from its power source and reattach the Power Head Lid
12. Restore power to the unit and verify that the unit is operating correctly.

2. Remove the Power Head Lid following the instructions provided in the **Panels and Covers** section of this manual.
3. Remove the left side panel using the procedures provided in the **Panels and Covers** section of this manual.
4. Locate the Drain Tube and place it into an empty pan.

PLUMBING COMPONENTS



WARNING

Before removing any sheet metal panels or servicing this equipment, always perform the Electrical LOCKOUT/TAGOUT Procedure. Be sure all circuits are disconnected. Failure to comply with this procedure can cause property damage, injury or death.



WARNING

Certain components may be hot if the unit was in operation prior to performing a procedure. Allow the unit to cool before beginning work.



WARNING

Before servicing the plumbing system the heat transfer fluid must be drained from the system.

B&G PUMP

NOTICE: In BW5SNDNL models the B&G Pump and Heater Tank are located at the back of the unit. Removal of the Back Panel is required when servicing the B&G Pump or Heater Tank Components.

Additional tools required for this procedure:

- 1-1/16 Wrench
- 1-3/8 Wrench
- 7/16 Wrench

1. Follow the LOCKOUT/TAGOUT procedure using the procedures provided in the **Lockout/Tagout Procedures** section of this manual.

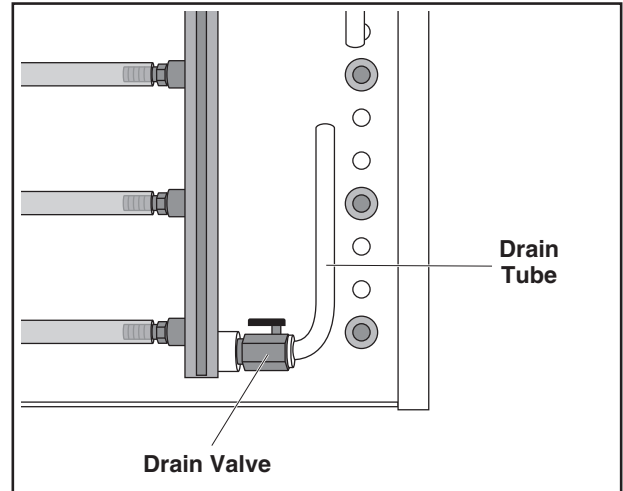

Figure 15: Drain Tube & Drain Valve Location

5. Remove the Heater Tank Cap and the Reservoir Cap.

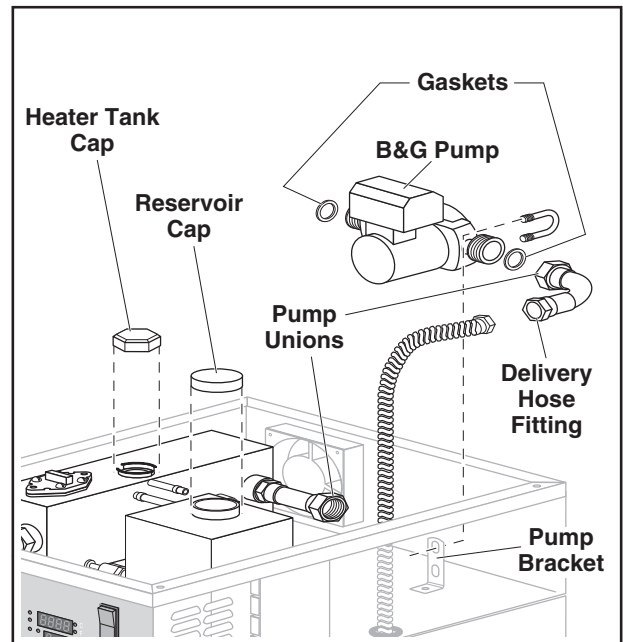

Figure 16: B&G Pump Removal

6. Open the Drain Valve to drain the Heat Transfer Fluid.

-
7. Discard the drained fluid; refer to the **Heat Transfer Fluid Material Safety Data Sheet** provided in this manual for proper disposal of fluid.
 8. Tag and disconnect the B&G pump wires.
 9. Using the 1-1/16 wrench, remove the Delivery Line.
 10. Using the 1-3/8 wrench, unscrew the unions on both sides of the pump.
 11. Using the 7/16 wrench, remove the U-clamp securing the pump to the Pump Bracket and remove the pump
 12. Place the new pump into position.
 13. Loosely connect the U-clamp.
 14. Ensure NEW gaskets are in place at both unions, tighten the unions using the 1-3/8 wrench.
 15. Tighten the 7/16 nuts on the U-clamp.
 16. Reconnect the Delivery Line.
 17. Referring to the tags or circuit schematic reconnect the pump wires.
 18. Close the Drain Valve
 19. Restore power to the unit.
 20. Fill the Heater Tank with FRESH Heat Transfer Fluid and replace the Heater Tank Pressure Cap.
 21. Fill the Reservoir Tank until the Add Fluid Light goes out and replace the Reservoir Tank Cap.
 22. Ensure there are no leaks at the pump unions or Delivery Line fitting.
 23. Remove the unit from its power source.
 24. Reattach all covers and panels.
 25. Restore the unit's power, check it for proper operation. It may be necessary to add additional fluid after the unit has operated for several minutes.



WARNING

Before removing any sheet metal panels or servicing this equipment, always perform the Electrical LOCKOUT/TAGOUT Procedure. Be sure all circuits are disconnected. Failure to comply with this

procedure can cause property damage, injury or death.



WARNING

Certain components may be hot if the unit was in operation prior to performing a procedure. Allow the unit to cool before beginning work.



WARNING

Before servicing the plumbing system the heat transfer fluid must be drained from the system.

TEFLON HOSES

Under normal operating circumstances it should not be necessary to replace a hose. Should a hose become damaged or begin leaking it must be replaced. There are two sets of Teflon Hoses installed on each unit. The short Teflon Hoses are located on the delivery side (left side) of the unit. The long Teflon Hoses are located on the return side (right side) of the unit. Both sets of hoses are replaced in the same manner.

1. Follow the LOCKOUT/TAGOUT procedure using the procedures provided in the **Lockout/Tagout Procedures** section of this manual.
2. Remove the Power Head Lid following the instructions provided in the **Panels and Covers** section of this manual.
3. Remove the left side panel using the procedures provided in the **Panels and Covers** section of this manual.
4. Locate the Drain Tube and place it into an empty pan.
5. Remove the Heater Tank Cap and the Reservoir Cap.
6. Open the Drain Valve to drain the Heat Transfer Fluid.
7. Discard the drained fluid; refer to the **Material Safety Data Sheet** provided in this manual for proper disposal of fluid.
8. Using a 3/4 open end wrench remove the hose

from the Shelf Elbow side first.

- Using a 7/16 open end wrench remove the hose from the manifold.

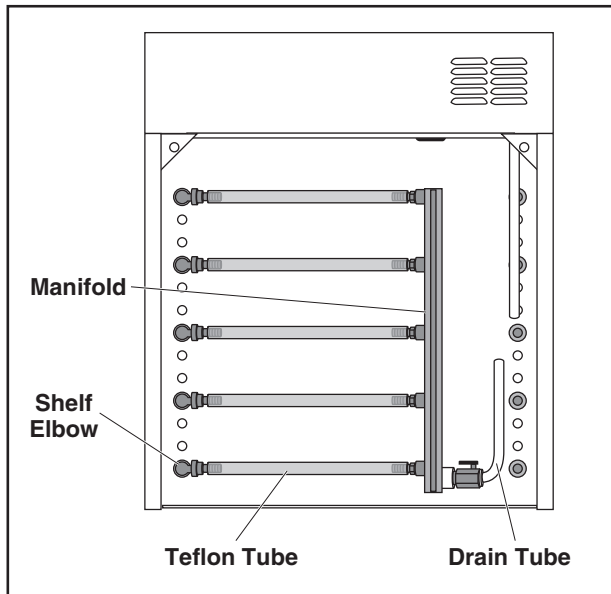

Figure 17: Return Side of Unit

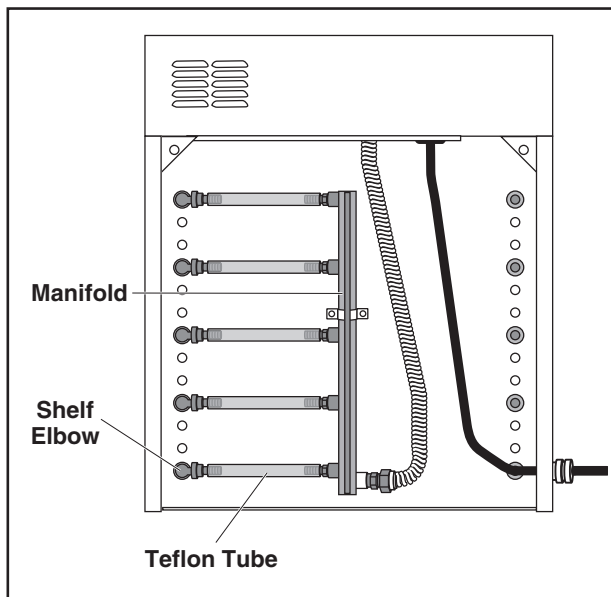

Figure 18: Delivery Side of Unit

- Attached the replacement Teflon Hose to the manifold first, than attach the other end to the Shelf Elbow using the appropriate wrenches.
- Close the Drain Valve
- Restore power to the unit.

- Fill the Heater Tank with FRESH Heat Transfer Fluid and replace the Heater Tank Pressure Cap.
- Fill the Reservoir Tank until the Add Fluid Light goes out and replace the Reservoir Tank Cap.
- Ensure there are no leaks around the fittings of the new hose.
- Remove the unit from its power source.
- Reattach all covers and panels.
- Restore the unit's power, check it for proper operation. It may be necessary to add additional fluid after the unit has operated for several minutes.
- After the unit has operated for several minutes remove the Side Panel where the hose was replaced and ensure that it is not leaking. Tighten as necessary.
- Reattach the removed Side Panel.

! WARNING

Before removing any sheet metal panels or servicing this equipment, always perform the Electrical LOCKOUT/TAGOUT Procedure. Be sure all circuits are disconnected. Failure to comply with this procedure can cause property damage, injury or death.

! WARNING

Certain components may be hot if the unit was in operation prior to performing a procedure. Allow the unit to cool before beginning work.

! WARNING

Before servicing the plumbing system the heat transfer fluid must be drained from the system.

FLUID LEVEL PROBES

There are two Fluid Level Probes. One is installed in the Heater Tank, the other is installed in the Reservoir Tank. Before changing either of the probes check the fluid levels in the Heater Tank and the Reservoir Tank. Also, check the electrical

connection to the probes. The probes should test as open with a continuity test when the tanks are filled with fluid. With an empty tank the probe should test as closed during a continuity test.

NOTICE: In BW5SNDNL models the B&G Pump and Heater Tank are located at the back of the unit. Removal of the Back Panel is required when servicing the B&G Pump or Heater Tank Components.

1. Follow the LOCKOUT/TAGOUT procedure using the procedures provided in the **Lockout/Tagout Procedures** section of this manual.
2. Remove the Power Head Lid following the instructions provided in the **Panels and Covers** section of this manual.
3. Remove the left side panel using the procedures provided in the **Panels and Covers** section of this manual.
4. Locate the Drain Tube and place it into an empty pan.
5. Remove the Heater Tank Cap and the Reservoir Cap.
6. Open the Drain Valve to drain the Heat Transfer Fluid.
7. Discard the drained fluid; refer to the **Material Safety Data Sheet** provided in this manual for proper disposal of fluid.

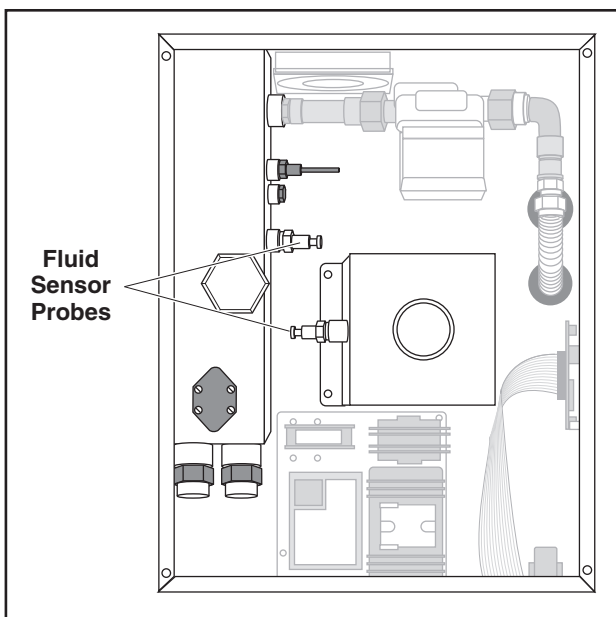

Figure 19: Fluid Sensor Probes

8. Disconnect the Fluid Sensor Probe lead.

9. Remove the defective probe.
10. Install the new probe.
11. Reconnect the probe lead.
12. Restore power to the unit.
13. Close the fluid Drain Valve.
14. Fill the Heater Tank and Reservoir Tank with fluid until the Low Fluid Light goes out.
15. Ensure that there are no leaks around the newly installed probe, tighten as needed.
16. Remove the unit from its power source.
17. Reattached the Side Panel and Power Head Cover.
18. Restore power to the unit and verify the unit is operating correctly. It may be necessary to add additional fluid after the unit has operated for several minutes.



WARNING

Before removing any sheet metal panels or servicing this equipment, always perform the Electrical LOCKOUT/TAGOUT Procedure. Be sure all circuits are disconnected. Failure to comply with this procedure can cause property damage, injury or death.



WARNING

Certain components may be hot if the unit was in operation prior to performing a procedure. Allow the unit to cool before beginning work.



WARNING

Before servicing the plumbing system the heat transfer fluid must be drained from the system.

SNAP DISC

The Snap Disc is located on the Heater Tank and provides over temperature protection for the unit.

NOTICE: In BW5SNDNL models the B&G Pump and Heater Tank are located at the back of the unit. Removal of the Back Panel is required when servicing the B&G Pump or Heater Tank Components.

1. Follow the LOCKOUT/TAGOUT procedure using the procedures provided in the **Lockout/Tagout Procedures** section of this manual.
2. Remove the Power Head Lid following the instructions provided in the **Panels and Covers** section of this manual.
3. Remove the left side panel using the procedures provided in the **Panels and Covers** section of this manual.
4. Locate the Drain Tube and place it into an empty pan.
5. Remove the Heater Tank Cap and the Reservoir Cap.
6. Open the Drain Valve to drain the Heat Transfer Fluid.
7. Discard the drained fluid; refer to the **Material Safety Data Sheet** provided in this manual for proper disposal of fluid.
8. Tag and disconnect the Snap Disc wires.

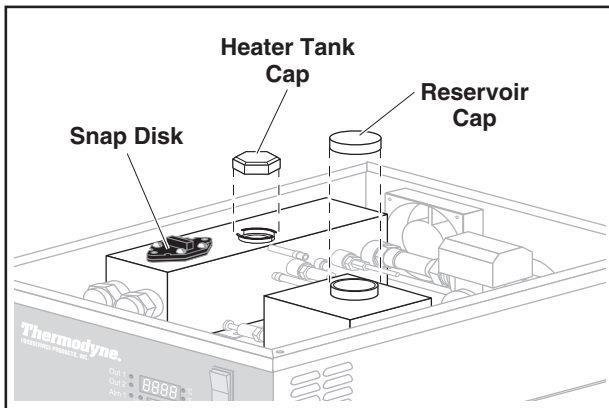

Figure 20: Location of Snap Disc

9. Remove the defective Snap Disc.
10. Install the new Snap Disc.
11. Referring to the tags or circuit schematic reconnect the wires to the Snap Disc.

12. Restore power to the unit.
13. Close the fluid Drain Valve.
14. Fill the Heater Tank and Reservoir Tank with fluid until the Low Fluid Light goes out.
15. Ensure that there are no leaks around the newly installed probe, tighten as needed.
16. Remove the unit from its power source.
17. Reattach the Side Panel and Power Head Cover.
18. Restore power to the unit and verify the unit is operating correctly. It may be necessary to add additional fluid after the unit has operated for several minutes.

 **WARNING**

Before removing any sheet metal panels or servicing this equipment, always perform the Electrical LOCKOUT/TAGOUT Procedure. Be sure all circuits are disconnected. Failure to comply with this procedure can cause property damage, injury or death.

 **WARNING**

Certain components may be hot if the unit was in operation prior to performing a procedure. Allow the unit to cool before beginning work.

 **WARNING**

Before servicing the plumbing system the heat transfer fluid must be drained from the system.

THERMOCOUPLE

The Thermocouple is located on the Heater Tank.

NOTICE: In BW5SNDNL models the B&G Pump and Heater Tank are located at the back of the unit. Removal of the Back Panel is required when servicing the B&G Pump or Heater Tank Components.

1. Follow the LOCKOUT/TAGOUT procedure using the procedures provided in the **Lockout/Tagout Procedures** section of this manual.
2. Remove the Power Head Lid following the instructions provided in the **Panels and Covers**

section of this manual.

3. Remove the left side panel using the procedures provided in the **Panels and Covers** section of this manual.
4. Locate the Drain Tube and place it into an empty pan.
5. Remove the Heater Tank Cap and the Reservoir Cap.
6. Open the Drain Valve to drain the Heat Transfer Fluid.
7. Discard the drained fluid; refer to the **Material Safety Data Sheet** provided in this manual for proper disposal of fluid.
8. The TBC-41 Controller is very easy to remove. There are four springs and spacers apiece holding the display and power boards. They are different lengths: the spacers used with the power board are 1/2" (12.7mm) long; the springs used with the display board are 5/16" (8mm) long.

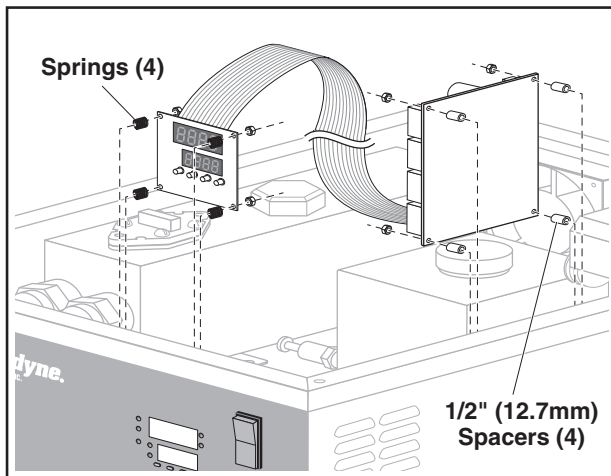

Figure 21: Controller

9. Note the location of and colors of the Thermocouple wires on the Controller.
10. Remove the wires for the Controller terminals.
11. Remove the Thermocouple from the Heater Tank.

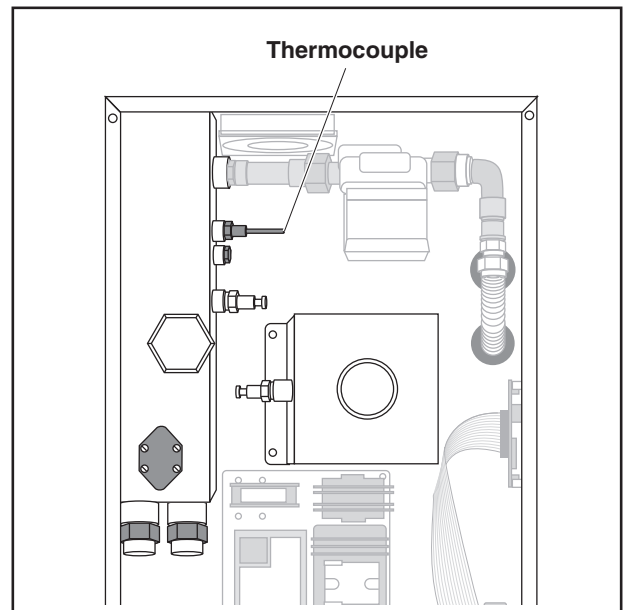

Figure 22: Location of Thermocouple

12. Install the new Thermocouple into the Heater Tank; be careful not to damage the Thermocouple lead while performing this task.
13. Referring to the note made in step 9 or the circuit schematic, connect the new Thermocouple leads to the Controller terminals.
14. Restore power to the unit.
15. Close the fluid Drain Valve.
16. Fill the Heater Tank and Reservoir Tank with fluid until the Low Fluid Light goes out.
17. Ensure that there are no leaks around the newly installed Thermocouple, tighten as needed.
18. Remove the unit from its power source.
19. Reattached the Side Panel and Power Head Cover.
20. Restore power to the unit and verify the unit is operating correctly. It may be necessary to add additional fluid after the unit has operated for several minutes.



WARNING

Before removing any sheet metal panels or servicing this equipment, always perform the Electrical LOCKOUT/TAGOUT Procedure. Be sure all circuits are disconnected. Failure to comply with this procedure can cause property damage, injury or death.



WARNING

Certain components may be hot if the unit was in operation prior to performing a procedure. Allow the unit to cool before beginning work.



WARNING

Before servicing the plumbing system the heat transfer fluid must be drained from the system.

HEAT ELEMENTS

The Heat Elements are located inside of the Heater Tank. The Heater Tank must be removed to gain access to the Heat Elements. Use this procedure to replace a Heat Element. Before performing this procedure check each Heat Element with a continuity meter. It is only necessary to replace the faulty element.

NOTICE: In BW5SNDNL models the B&G Pump and Heater Tank are located at the back of the unit. Removal of the Back Panel is required when servicing the B&G Pump or Heater Tank Components.

1. Follow the LOCKOUT/TAGOUT procedure using the procedures provided in the **Lockout/Tagout Procedures** section of this manual.
2. Remove the Power Head Lid following the instructions provided in the Panels and Covers section of this manual.
3. Remove the left side panel using the procedures provided in the **Panels and Covers** section of this manual.
4. Locate the Drain Tube and place it into an empty pan.
5. Remove the Heater Tank Cap and the Reservoir Cap.
6. Open the Drain Valve to drain the Heat Transfer Fluid.
7. Discard the drained fluid; refer to the **Material Safety Data Sheet** provided in this manual for proper disposal of fluid.

8. Tag and disconnect the Snap Disc Leads, Fluid Level Probe wire, Heat Element leads, and the tank ground wire.

NOTE: It may not be necessary to remove the Thermocouple to change the Heat Elements. If Thermocouple needs to be removed refer to the **Thermocouple** replacement procedure in this manual.

9. Before removing the Heater Tank loosen the Heat Elements with an appropriately sized wrench.
10. Remove the nuts and bolts securing the Heater Tank to the Return Manifold.

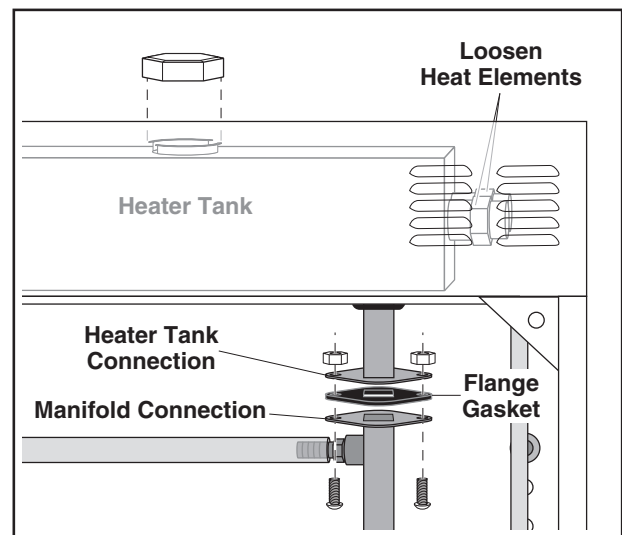

Figure 23: Heater Tank to Return Manifold Connection

11. Disconnect the Overflow Tube at the Pressure Cap on the Heater Tank
12. Completely loosen the Pump Union on the tank side of the pump.
13. Remove the nuts securing the Heater Tank to the unit's chassis.

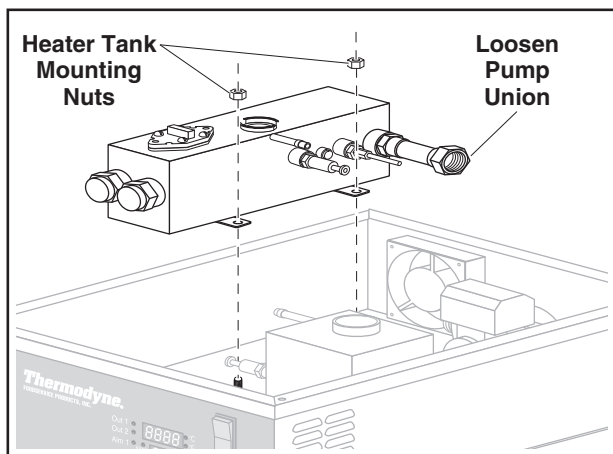

Figure 24: Heater Tank Removal

14. Carefully lift the Heater Tank out of the Power Head. If the Thermocouple is still attached be careful not to place undue stress on the Thermocouple wires.

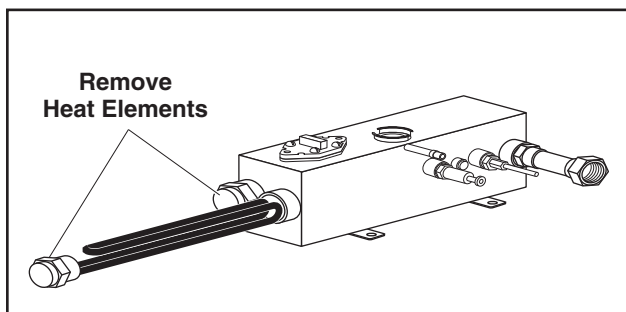

Figure 25: Heater Tank with Heat Elements Removed

15. Unscrew and remove the defective Heat Element.
16. Install the new Heat Element.

17. Using a NEW Flange Gasket reconnect the Heater Tank to the Return Manifold.
18. Reattach the Heater Tank to the Power Head chassis.
19. Tighten the Heat Element that was replaced.
20. Using a new Pump Union Gasket, reconnect the pump to the tank.
21. Reconnect the Overflow Tube.
22. Referring to the tags or the wiring schematic, reconnect all of the wires and leads. If the Thermocouple was removed, reinstall it.
23. Restore power to the unit and fill the Heater Tank and Reservoir Tank with fresh Heat Transfer fluid until the Low Fluid Level light goes out.
24. Check for leaks at the Return Manifold Flange, Pump Union, Heat Element and the Thermocouple if it was removed. Tighten as needed.
25. Remove the unit from its power source and reattach the left Side Panel and Power Head Cover.
26. Restore the unit to its power source and check the unit for proper operation. It may be necessary to add additional Heat Transfer Fluid after the unit has operated for several minutes.

MAINTENANCE PROCEDURES

TEMPERATURE CONTROLLER SET UP PROCEDURES

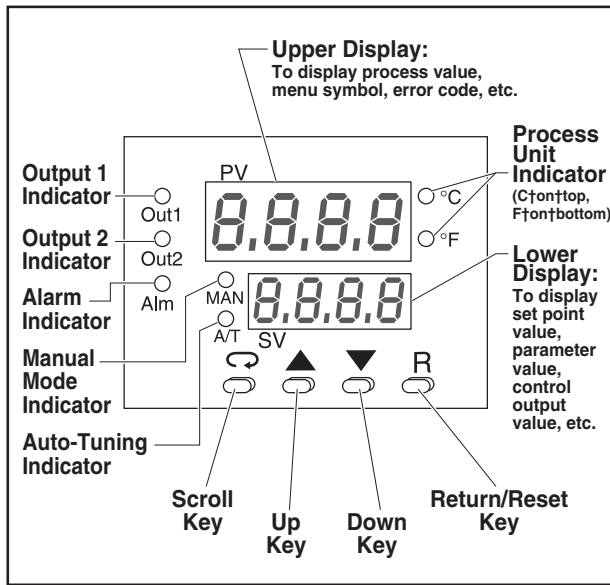

Figure 26: Controller

Keypad Operation

Scroll Key:

This key is used to select a parameter to be viewed or adjusted.

Up Key:

This key is used to increase the value of the selected parameter.

Down Key:

This key is used to decrease the value of the parameter.

Return / Reset Key: R

This key is used to:

1. Return the display to indicate the Process Value (PV) and Set Value (SV).
2. Reset a Latching Alarm once the alarm condition has cleared.
3. Discontinue Manual Control, Auto-Tuning and Calibration Modes.
4. Clear error messages indicating communication and auto-tuning errors.
5. Re-set the dwell timer function.
6. Enter the manual control menu if the sensor has failed.

Unlock the Controller

1. Follow the LOCKOUT/TAGOUT procedure using the procedures provided in the **LOCKOUT/TAGOUT Procedures** of this manual.
2. Remove the Power Head Lid following the instructions provided in the **Panels and Covers** section of this manual.
3. Enter the Set-Up Menu. With the unit under power, press the “Scroll” key for approximately 5 seconds until the upper display reads:

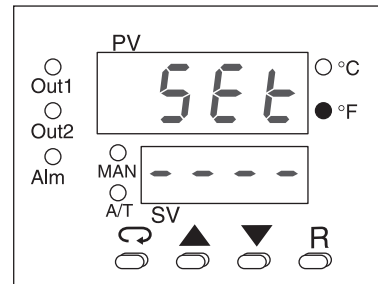

4. Press the “Scroll” key once. The upper display will read: “LOCK.” Press the “Down” key until the lower display reads: “nonE.” The controller is now unlocked. Press the “R” button to return controller to the home position of reading Process Value & Set Value. Also refer to pages 13 & 14 in the TBC-41 Instruction Manual for complete “LOCK” parameter choices.
5. Test the controller by trying to change the set temperature up and down.

Set-Up

1. Press the “Up” and “Down” key as needed to adjust the displayed set-point temperature.
2. The “OUT1” LED will be lit up solid during warm up. (normal operation)
3. When the “OUT1” LED is blinking, the unit has reached the desired temperature.

NOTE: This controller is not an indicator of fluid level in the Heater or Reservoir Tanks.

To Toggle Between °F and °C Readout:

1. Press the “Scroll” key 2 -3 times until the upper display reads: “unit”

- Press the “Up” or “Down” key to choose.

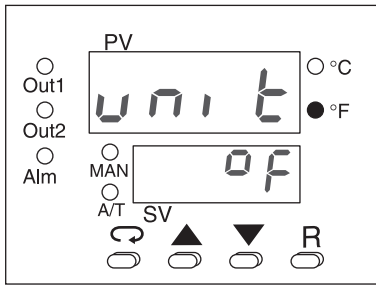

CHANGING THE HEAT TRANSFER FLUID

The Thermodyne Heat Transfer Fluid has lubricating additives, anti-corrosion additives, and heat transfer properties that protect the Thermodyne cabinet and help maintain the superior heat transfer capabilities of the system. Thermodyne recommends that the Thermodyne Heat Transfer Fluid be changed every 2 to 3 years under normal operating conditions – please consult with the a factory representative for more frequent changes when operating at above normal temperatures (i.e. 200 degrees) or extended hours of operation (i.e. 24/7).

NEVER SUBSTITUTE THERMODYNE HEAT TRANSFER FLUID WITH WATER OR OTHER LIQUID.

- Follow the LOCKOUT/TAGOUT procedure using the procedures provided in the **Lockout/Tagout Procedures** section of this manual.
- Remove the Power Head Lid following the instructions provided in the **Panels and Covers** section of this manual.
- Remove the left side panel using the procedures provided in the **Panels and Covers** section of this manual.
- Place the Drain Tube end into an empty pan.

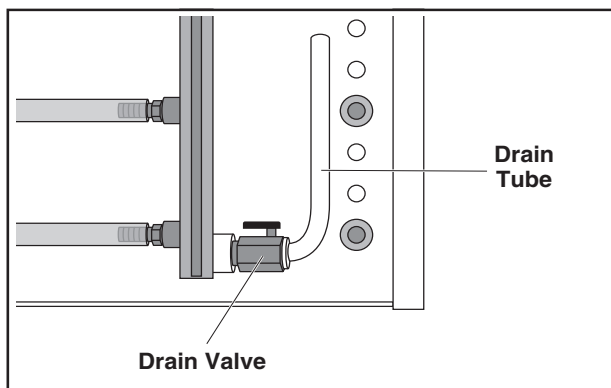

Figure 27: Drain Tube & Valve Location

- Remove the Heater Tank and Reservoir caps.

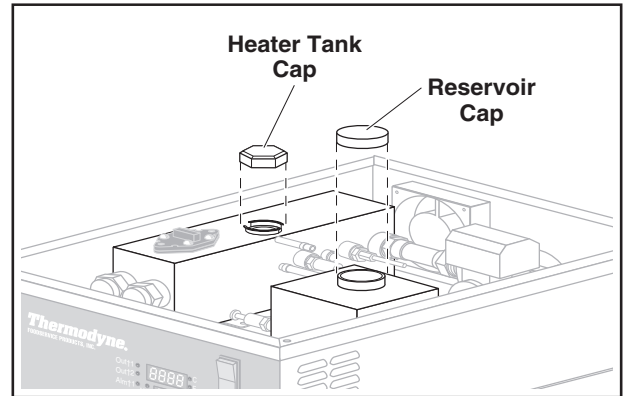

Figure 28: Heater Tank Cap & Reservoir Cap

- Open the Drain Valve to drain the Heat Transfer Fluid.
- Discard the drained fluid; refer to the **Material Safety Data Sheet** provided in this manual for proper disposal of fluid.
- Close the Drain Valve and stow the Drain Tube inside the cabinet.
- Replace the Side Panel and the Power Head Lid.
- Restore power to the unit and turn it on.
- Fill the Heater Tank and replace the Pressure Cap.
- Fill the Reservoir until the Add Fluid Light goes out and replace the Reservoir Cap.
- The Add Fluid Light may come on after a few minutes of operation. Remove the Fill Cap Cover on the Power Head Lid and the Reservoir Cap; top off the Reservoir until the Add Fluid Light goes out.
- Reattach the Fill Cap Cover to the Power Head Lid.

CT DOOR ADJUSTMENT

- Follow the LOCKOUT/TAGOUT procedure using the procedures provided in the **Lockout/Tagout Procedures** section of this manual.
- Allow the unit to cool.**
- Remove the Side Panels following the procedures provided in the **Covers and Panels** section of this manual.

4. Lift the door/s up and off of the unit.
5. Loosen the hinges on the unit.

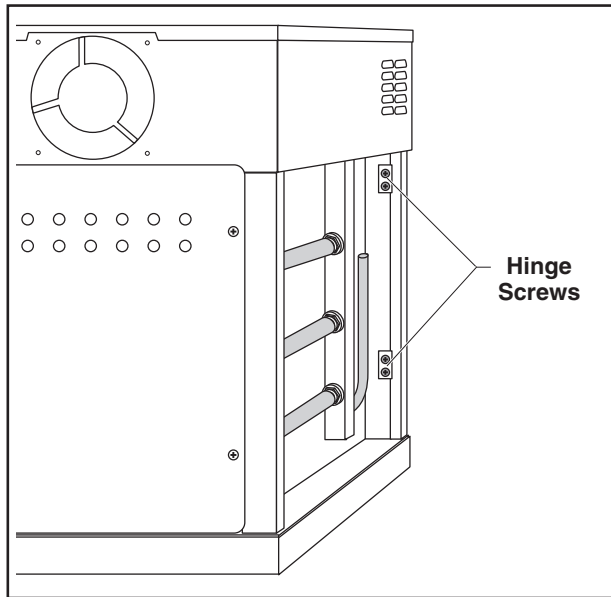

Figure 29: Location of Hinge Screws

6. Reattach the door/s to the loosened hinges.
7. Close the door/s and align them in the closed position.
8. Tighten the hinge screws.
9. Make sure the doors open and close properly.
10. Attach the Side Panels.
11. Restore the unit to its power source.

STAINLESS STEEL CARE

Cleaning

Stainless steel contains 70-80% iron, which will rust if not properly maintained. It also contains 12-30% chromium, which forms an invisible passive, protective film that shields against corrosion. If the film remains intact, the stainless steel will remain intact. However, if the film is damaged, the stainless steel can break down and rust. To prevent stainless steel breakdown, follow these steps:

CAUTION

Never use any metal tools. Scrapers, files, wire brushes or scouring pads (except for stainless steel scouring pads) will mar the surface.

CAUTION

Never use steel wool, which will leave behind particles that rust.

CAUTION

Never use acid-based or chloride-containing cleaning solutions, which will break down the protective film.

CAUTION

Never rub in a circular motion.

CAUTION

Never leave any food products or salt on the surface. Many foods are acidic. Salt contains chloride.

For routine cleaning, use warm water, mild soap or detergent and a sponge or soft cloth. For heavy-duty cleaning, use warm water, a degreaser and a plastic, stainless steel or Scotch-Brite pad. Always rinse thoroughly. Always rub gently in the direction of the steel grain.

Preserving & Restoring

Special stainless steel polishing cleaners can preserve and restore the protective film. Preserve the life of stainless steel with a regular application of a high quality stainless steel polishing cleaner as a final step to daily cleaning. If signs of breakdown appear, restore the stainless steel surface. First, thoroughly clean, rinse and dry the surface. Then, on a daily basis, apply a high-quality stainless steel polish according to manufacturer's instructions.

Heat Tint

Darkened areas, called heat tint, may appear on stainless steel exposed to excessive heat, which causes the protective film to thicken. It is unsightly but is not a sign of permanent damage. To remove heat tint, follow the routine cleaning procedure. Stubborn heat tint will require heavy-duty cleaning.

To reduce heat tint, limit the exposure of equipment to excessive heat.

TROUBLESHOOTING

Problem	Probable Cause	Suggested Solution
No Power	Main Power Switch Off	Place Power Switch in ON position.
	Unit not plugged in	Ensure unit is plugged into a live receptacle.
	Circuit Breaker off or tripped	Check and reset the Circuit Breaker.
	Contactor Failure	Replace the Contactor.
On/Off switch illuminated but controller will not illuminate	Heater Tank fluid level low	Remove unit from power source and fill Heater Tank to Pressure Cap neck with fresh Heat Transfer Fluid.
	Fluid Level Probe defective	Determine which Fluid Level Probe is defective and replace it.
Unit continuously shuts down and requires fluid replenishment – Or – Add Fluid light illuminates every couple of days	Fluid leak	Remove the unit from power and remove the Power Head Lid and Side Covers. Restore power and place the ON/OFF switch in its ON position. Observe the unit for leaks. Repair leak and top of fluid levels.
Add Fluid light is illuminated but unit is operating normally	Reservoir Tank low on fluid	Top off Reservoir with fresh Heat Transfer Fluid.
Unit not reaching desired temperature	Controller not set to 189°F.	Refer to Temperature Controller Set Up Procedures and set temperature to 189°F.
	Defective Controller	Refer to Temperature Controller replacement procedure and replace controller.
OUT light illuminated but unit not heating up	Defective Solid State Relay	Refer to Solid State Relay replacement procedure and replace relay. Note: If relay LED is illuminated check Snap Disc.
	Defective or tripped Snap Disc	Reset Snap Disc. If unit fails to warm up, replace Snap Disc.
Some shelves heat while others remain cold	Shelf or Delivery/Return Hose is plugged.	Replace defective shelf or defective hose. Note: Delivery and Return hoses are different lengths.
Extreme Electrical Load, clicking noise or controller turning on and off	Fluid Level in Heater Tank low	Remove unit from power and top off Heater Tank with fresh Heat Transfer Fluid.
	Faulty Contactor	Replace the Contactor.
Loud Squealing Noise	Defective Pressure Cap or Pressure Cap Gasket	Replace the 16 PSI Pressure Cap. Replace the defective pump referring to the pump replacement procedures.
	Defective Pump	
Controller reads SBER on top screen	Defective Thermocouple	Refer to Thermocouple replacement procedure and replace the Thermocouple.

WIRING SCHEMATIC

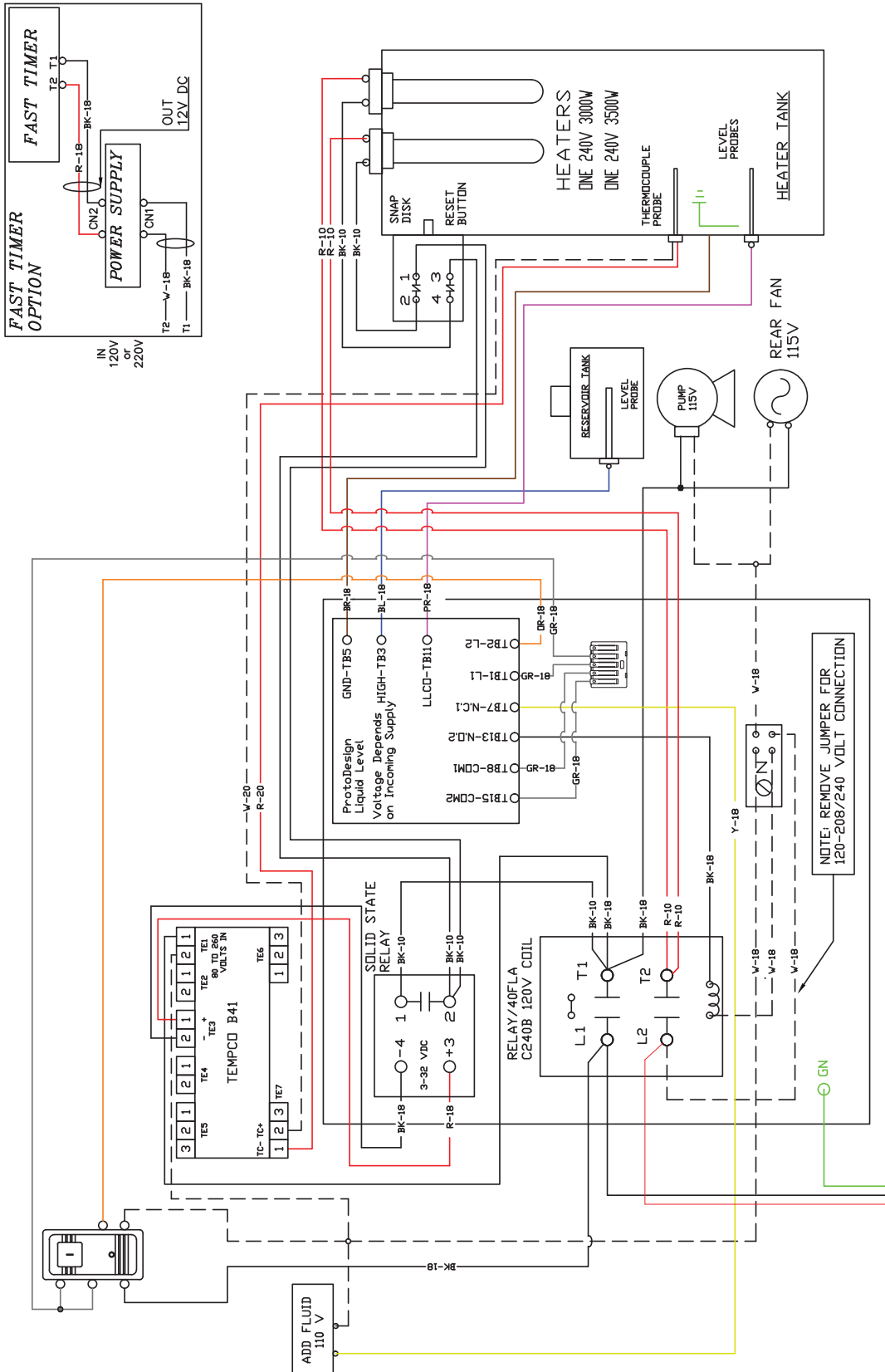

Standard Wiring

THERMODYNE FOOD SERVICE PRODUCTS INC.	
TITLE	
STANDARD OVEN WIRING DIAGRAM	
120/208/240 VOLT UNITS	
SIZE	REV
CAGE CODE/DWG. NO	USA 1-Phase
SCALE	8
DATE: 9-10-21	SHEET

PRIMARY POWER BOARD

5-15 PLUG FOR USA / 5-20 PLUG FOR CANADA

FOR REFERENCE ONLY:
 POWER CORD 3-WIRE 12 GA. - 15 AMP
 POWER CORD 4-WIRE 10 GA. - 26 AMP

TO POWER BOARD TERMINALS

L1 L2 N
 BK R W GN
 120 VOLT SUPPLY

NOTE: REMOVE JUMPER FOR 120-208/240 VOLT CONNECTION

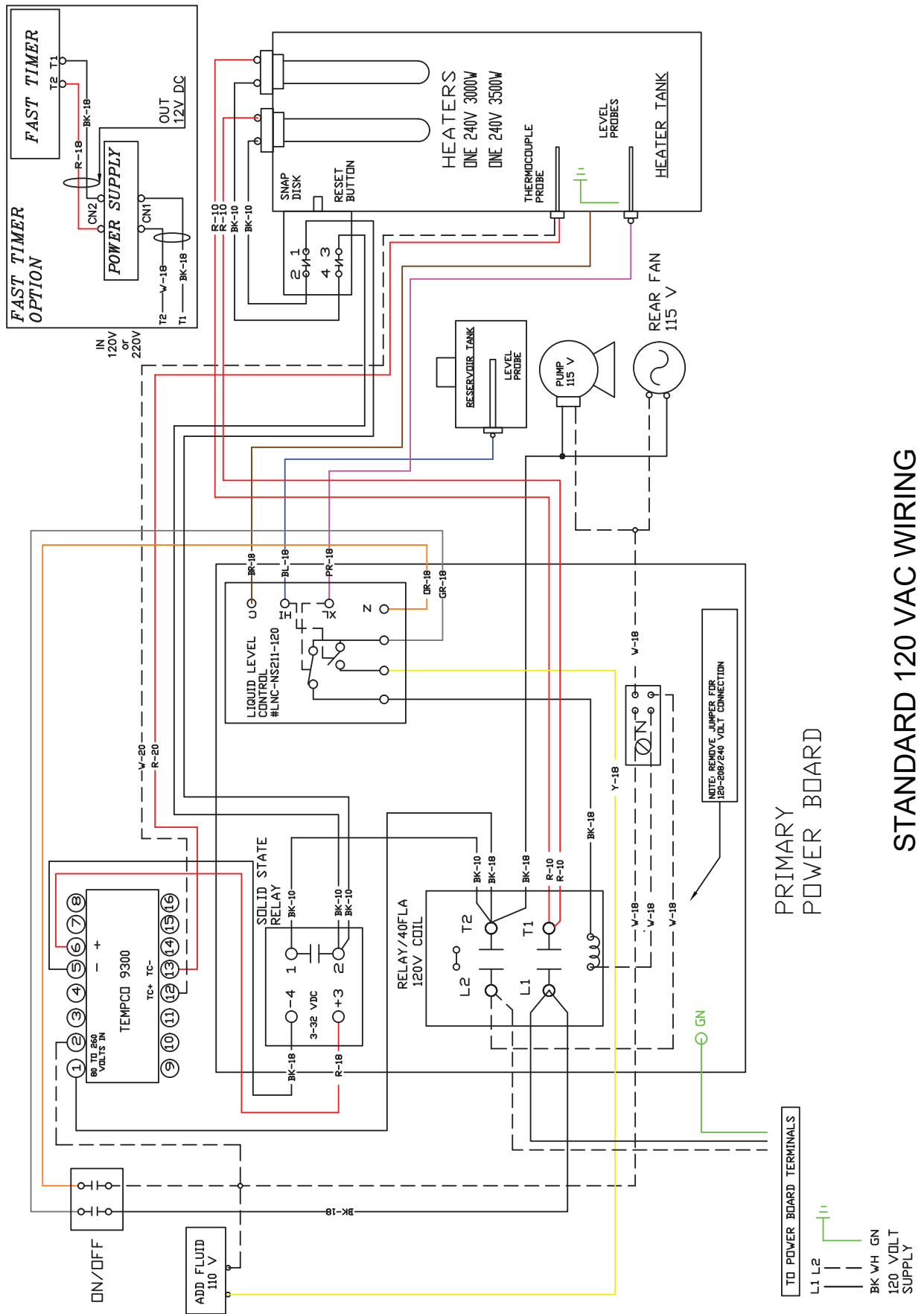

Standard 120 VAC Wiring

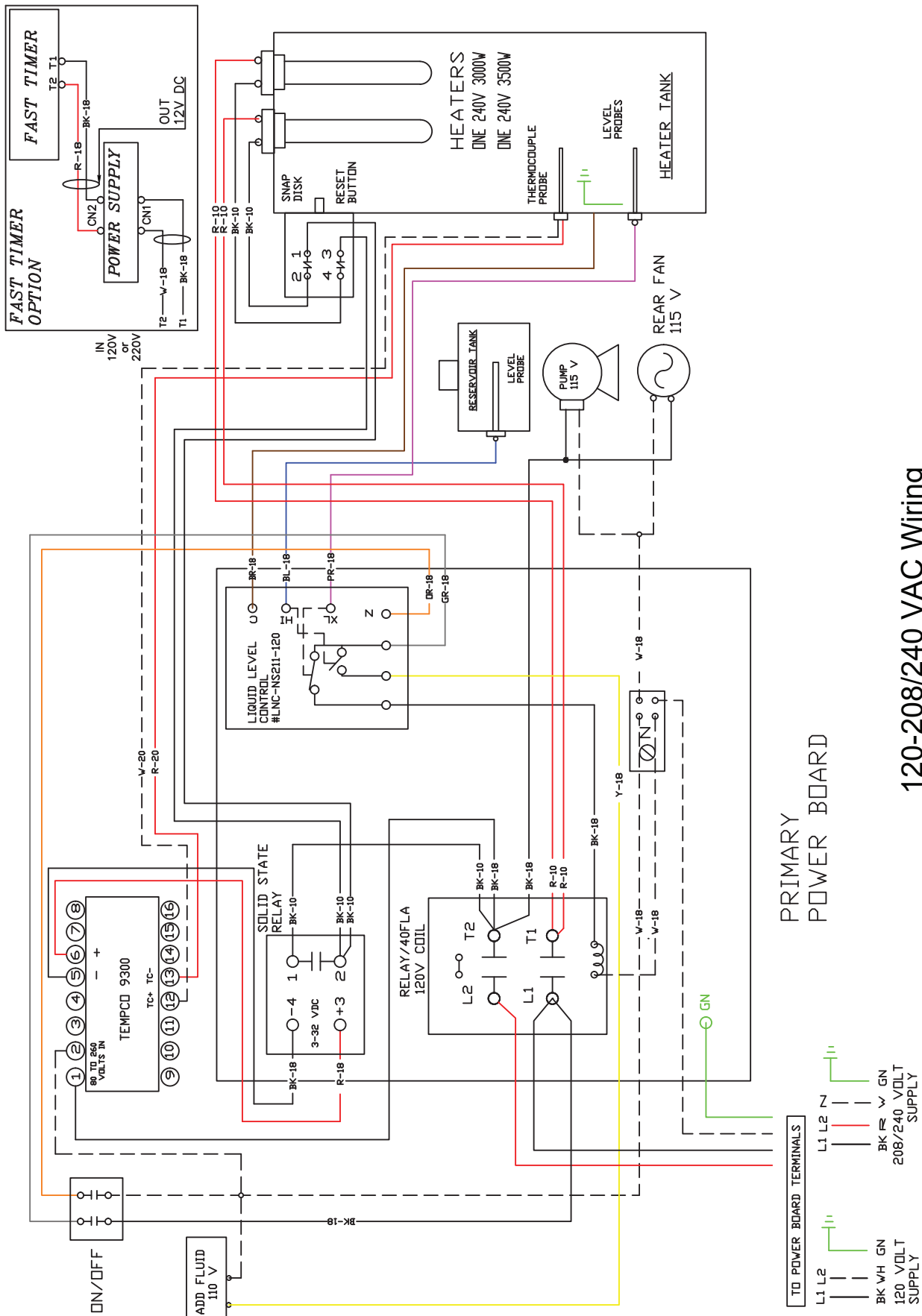

120-208/240 VAC Wiring

PRIMARY
POWER BOARD

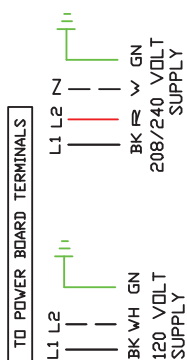

120-208/240 VAC Wiring

FLUID CAPACITIES (STANDARD SHELF CONFIGURATION)

MODEL	GALLONS	LITERS	PER SHELF (OZ)
125OC	1.5	3.78	14
200NDNL	1.75	6.62	6
200CT	1.75	6.62	6
250OC	1.65	6.62	20
250PNDT	2.1	7.95	6
BW3	1.65	6.25	6
BW4	1.7	6.44	6
300NDNL	1.91	7.23	6
300CT	1.91	7.23	6
700NDNL	2.25	8.52	14
700CT	2.25	8.52	14
950NDNL	2.16	8.18	20
300OC	2.24	8.48	14
1200G	2.22	8.40	13

MODEL	GALLONS	LITERS	PER SHELF (OZ)
1200DW	2.3	8.71	14
1300G	2.32	8.78	13
1600NDNL	2.1	7.95	6
1900G	3.02	11.43	13
1900DW	3.06	11.58	14
2100DW	3.59	13.59	20
6000P	4.95	18.74	23.8
700DP	2.25	8.52	14
1500DP	3.01	11.39	14
742HW	2.45	9.27	14
744HW	3	11.36	28
1600HZ	2.5	9.46	Top-14; Bottom-6

WARRANTY

Thermodyne Foodservice Products, Inc. warrants to the original purchaser for use of each new Thermodyne Conductive Cooking/Holding Oven the following: Any part which proves to be defective in materials or workmanship within the warranty period will, subject to the terms of this warranty, be repaired or replaced at Thermodyne Foodservice, Inc.'s option. Claims under this warranty must be presented to Thermodyne Foodservice Products, Inc. in writing, promptly.

Thermodyne stainless steel cabinets are warranted for 5 years and all other original equipment parts such as heat transfer plates, doors, casters, fluid system components and electrical components are warranted against defect for one year from the date of purchase.

This warranty applies only to Thermodyne Conductive Cooking/Holding Ovens in the Continental United States. This warranty shall not apply if the oven or any part is subjected to accident, casualty, alteration, misuse, abuse, neglect, faulty installation, or if the date of manufacture is altered or removed. Thermodyne will cover service agents travel up to 60 miles, any cost associated with travel from over 60 miles will be covered by purchaser.

The obligation of Thermodyne Foodservice Products, Inc. is limited specifically to the aforementioned. No additional guarantees or warranty, expressed or implied, to include without limitation warranties of Fitness or Merchantability with respect to Thermodyne Conduction Ovens and Thermodyne Foodservice Products, Inc. regarding other liability with respect thereto including, without limitation, liability for incidental, special, or consequential damages.

RESPONSIBILITIES OF PURCHASER

It is the responsibility of the purchaser to:

1. Arrange on site electrical services in accordance with Thermodyne specifications.
2. Receive shipment of Thermodyne conduction oven to include unloading, uncrating, inspecting for damage in shipment, and installation of the oven in its proper location; in accordance with installation instructions.
3. Arrange that the electric services are connected properly by a qualified technician. All such connections must be in accordance with applicable code requirements and Thermodyne installation procedures.

Please note the specific details on the Warranty and make certain that service connections are made to the proper utility services. This warranty and purchasers responsibility information should be retained for future reference.

For assistance please call:

Toll Free: (800) 526-9182
Local: (260) 428-2535

HEAT TRANSFER FLUID MSDS

Dow Chemical U.S.A.
Midland, MI 48674
Emergency Phone: 517-636-4400
Product Code: 23545
Product Name: PROPYLENE GLYCOL
HEAT TRANSFER FLUID
Effective Date: 03-02-88
Date Printed: 06/02/88
MSDS: 000130

1. **INGREDIENTS:**
Propylene glycol CAS# 000057-55-6 95%
Dipotassium phosphate CAS# 007758-11-4 <5%
Deionized water CAS# 007732-18-5 <5%

This document is prepared pursuant to the OSHA Hazard Communication Standard (29CFR 1910.1200). In addition, other substances not 'Hazardous' per this OSHA Standard may be listed. Where proprietary ingredient shows, the identity may be made available as provided in this standard.

2. **PHYSICAL DATA:**
BOILING POINT: 370F, 188C
VAP. PRESS: 0.22 mmHg @ 20C, 68F
VAP. DENSITY: 2.62
SOL. IN WATER: Complete
SP. Gravity: 1,050 @ 60/60F, 16C
APPEARANCE: Colorless.
ODOR: Odorless liquid.
3. **FIRE AND EXPLOSION HAZARD DATA:**
FLASH POINT: 215F, 102C
METHOD USED: COC
FLAMMABLE LIMITS
LFL: 2.6% @ 100C
UFL: 12.5% @ 130C
EXTINGUISHING MEDIA: Water fog, alcohol foam, dry chemical
FIRE AND EXPLOSION HAZARDS: None.
FIRE-FIGHTING EQUIPMENT: None.
4. **REACTIVITY DATA:**
STABILITY: (CONDITIONS TO AVOID)
Stable over normal
Operating temperature range of -30F to 250F.
INCOMPATIBILITY: (SPECIFIC MATERIALS TO AVOID)
Oxidizing material.
HAZARDOUS DECOMPOSITION PRODUCTS: None
HAZARDOUS POLYMERIZATION: Will not occur,
5. **ENVIRONMENTAL AND DISPOSAL INFORMATION:**
ACTION TO TAKE FOR SPILLS/LEAKS: Cover with absorbent material, soak up and sweep into bag.
6. **HEALTH HAZARD DATA:**
EYE: May cause slight transient eye irritation. Corneal injury is unlikely.
SKIN CONTACT: Essentially nonirritating to skin on prolonged contact.
SKIN ABSORPTION: A single prolonged skin exposure is not likely to result in absorption of harmful amounts. The LD50 for skin absorption in rabbits is >10,000 mg/kg.

Repeated exposures may cause slight flaking, tenderness and softening of skin.
INGESTION: Single does oral toxicity is low. The LD50 for female rats is about 20.3 g/kg

INHALATION: A single prolonged (hours) inhalation exposure is not likely to cause adverse side effects. Mists are not to be hazardous.

SYSTEMIC & OTHER EFFECTS:
Repeated excessive ingestion may cause central nervous system effects. No carcinogenic effects have been seen in long-term animal studies. Birth defects are unlikely. Exposures having no adverse effects on the mother should have no effect on the fetus. In animal studies, has been shown not to interfere with reproduction. Results of mutagenicity tests in vitro (test tube) and in animals have been negative.

7. **FIRST AID**
EYES: Irrigate immediately with water for at least 5 minutes.
SKIN: wash off in flowing water or shower
INGESTION: Induce vomiting if large amounts are ingested, consult medical
INHALATION: Remove to fresh air if effects occur. Consult medical.
NOTE TO PHYSICIAN: No specific antidote. Supportive care. Treatment based on judgment of the physician in response to reactions of the patient.
8. **HANDLING PRECAUTIONS:**
EXPOSURE GUIDELINE (S): Dow IHG is 10mg/m3 for propylene glycol mist. Dow IHG 440 ppm for propylene glycol vapors.
VENTILATION: Good general ventilation sufficient.
RESPIRATORY PROTECTION: No respiratory protection should be needed.
SKIN PROTECTION: No precautions other than clean body covering should be needed.
EYE PROTECTION: Use safety glasses.
9. **ADDITIONAL INFORMATION:**
REGULATORY REQUIREMENTS:
SARAHAZARDCATEGORY: This product has been reviewed according to the EPA 'Hazard Categories' promulgated under Section 311 and 312 of the Superfund Amendment and Reauthorization Act of 1986 (SARA Title III) and is considered, under applicable definitions, to meet the following categories: A delayed hazard.
SPECIAL PRECAUTIONS TO BE TAKEN IN HANDLING AND STORAGE: Exercise reasonable care and caution.
MSDS STATUS: Revised Section 9