



# SERVICE MANUAL



## MODELS

1200 G	1200 DW	3000 P
1300 G	1900 DW	6000 P
1900 G	2100 DW	

For additional information on Thermodyne Foodservice Products, Inc.,  
or to locate an authorized parts and service provider in your area,  
visit our website at [www.tdyne.com](http://www.tdyne.com).

Please visit our website to Register your Thermodyne unit. Registration ensures that you  
get up-to-date warranty and product information, along with fast and convenient service.

<http://www.tdyne.com/register.aspx>

Thermodyne Foodservice Products, Inc.  
4418 New Haven Avenue  
Fort Wayne, IN 46803

1-800-526-9182  
[www.tdyne.com](http://www.tdyne.com)

---

## ELECTRICAL WARNINGS

THIS MANUAL HAS BEEN PREPARED FOR PERSONNEL QUALIFIED TO INSTALL ELECTRICAL EQUIPMENT, WHO SHOULD PERFORM THE INITIAL FIELD STARTUP AND ADJUSTMENTS OF THE EQUIPMENT COVERED BY THIS MANUAL.

READ THIS MANUAL THOROUGHLY BEFORE OPERATING, INSTALLING OR PERFORMING MAINTENANCE ON THE EQUIPMENT.



**WARNING:** Failure to follow all the instructions in this manual can cause property damage, injury or death.



**WARNING:** Improper installation, adjustment, alteration, service or maintenance can cause property damage, injury or death.



**WARNING:** Electrical connections should be performed only by a certified professional.



**WARNING:** Electrical and grounding connections must comply with the applicable portions of the National Electric Code and/or all local electric codes. Failure to comply with this procedure can cause property damage, injury or death.



**WARNING:** Before connecting the unit to the electrical supply, verify that the electrical and grounding connections comply with the applicable portions of the National Electric Code and/or other local electrical codes. Failure to comply with this procedure can cause property damage, injury or death.



**WARNING:** Before connecting the unit to the electrical supply, verify that the electrical connection agrees with the specifications on the data plate. Failure to comply with this procedure can cause property damage, injury or death.



**WARNING:** UL73 grounding instructions: This appliance must be connected to a grounded, metal, permanent wiring system. Or an equipment-grounding conductor must be run with the circuit conductors and connected to the equipment-grounding terminal or lead on the appliance. Failure to comply with this procedure can cause property damage, injury or death.



**WARNING:** Appliances equipped with a flexible electric supply cord, are provided with a three-prong grounding plug. It is imperative that this plug be connected into a properly grounded three-prong receptacle. Failure to comply with this procedure can cause property damage, injury or death.



**WARNING:** If the receptacle is not the proper grounding type, contact an electrician. Do not remove the grounding prong from the plug. Failure to comply with this procedure can cause property damage, injury or death.



**WARNING:** Before performing any service that involves electrical connection or disconnection and/or exposure to electrical components, always perform the Electrical LOCKOUT/TAGOUT Procedure. Disconnect all circuits. Failure to comply with this procedure can cause property damage, injury or death.



**WARNING:** Before removing any sheet metal panels, always perform the Electrical LOCKOUT/TAGOUT Procedure. Be sure all circuits are disconnected. Failure to comply with this procedure can cause property damage, injury or death.



**WARNING:** Do not operate this equipment without properly placing and securing all covers and access panels. Failure to comply with this procedure can cause property damage, injury or death.



**WARNING:** Do not use or store gasoline or other flammable vapors or liquids in the vicinity of this or any other appliance. Failure to comply can cause property damage, injury or death.



**WARNING:** In the event of a power failure, do not attempt to operate this appliance. Failure to comply can cause property damage, injury or death.

---

# TABLE OF CONTENTS

ELECTRICAL LOCKOUT/TAGOUT PROCEDURE .....	5
COVERS AND PANELS .....	6
Top Fill Cover .....	6
Power Head Lid.....	6
Side Panels .....	7
Doors.....	7
COMPONENT LOCATOR.....	8
Power Head Components .....	8
Delivery Manifold Components .....	9
Return Manifold Components .....	10
COMPONENT REMOVAL AND REPLACEMENT.....	11
ELECTRICAL COMPONENTS .....	11
Power Toggle Switch.....	11
Add Fluid Light.....	11
Temperature Controller .....	12
Cooling Fan .....	13
Power Cord .....	14
POWER BOARD COMPONENTS .....	14
Solid State Relay .....	14
Float Board .....	15
PLUMBING COMPONENTS .....	16
B&G Pump.....	16
Teflon Hoses .....	17
Fluid Level Probes .....	18
Snap Disc .....	19
THERMOCOUPLE.....	20
HEAT ELEMENTS.....	21
MAINTENANCE PROCEDURES .....	24
Temperature Controller Set Up Procedures.....	24
Keypad Operation .....	24
Set Up .....	24
Changing the Heat Transfer Fluid.....	24
Door Adjustment.....	26
Stainless Steel Care.....	27
TROUBLESHOOTING.....	28
WIRING SCHEMATICS .....	29
WARRANTY .....	31
HEAT TRANSFER FLUID MSDS .....	31

# ELECTRICAL LOCKOUT/TAGOUT PROCEDURE



## **WARNING**

**Before performing any service that involves electrical connection or disconnection and/or exposure to electrical components, always follow the Electrical LOCKOUT/TAGOUT Procedure. Disconnect all circuits. Failure to comply can cause property damage, injury or death.**

The Electrical LOCKOUT/TAGOUT Procedure is used to protect personnel working on an electrical appliance. Before performing any maintenance or service that requires exposure to electrical components, follow these steps:

1. In electrical box, place appliance circuit breaker into OFF position.
2. Place a lock or other device on electrical box cover to prevent someone from placing circuit breaker ON.
3. Place a tag on electrical box cover to indicate that appliance has been disconnected for service and power should not be restored until tag is removed by maintenance personnel.
4. Disconnect appliance power cord from electrical outlet.
5. Place a tag on the cord to indicate that unit has been disconnected for service and power should not be restored until tag is removed by maintenance personnel.

## FLUID CAPACITIES (STANDARD SHELF CONFIGURATION)

MODEL	GALLONS	LITERS	PER SHELF (OZ)
125 OC	1.5	3.78	14
200 NDNL	1.75	6.62	6
200 CT	1.75	6.62	6
250 OC	1.65	6.62	20
250 PNDT	2.1	7.95	6
BW3	1.65	6.25	6
BW4	1.7	6.44	6
300 NDNL	1.91	7.23	6
300 CT	1.91	7.23	6
700 NDNL	2.25	8.52	14
700 CT	2.25	8.52	14
950 NDNL	2.16	8.18	20
300 OC	2.24	8.48	14

MODEL	GALLONS	LITERS	PER SHELF (OZ)
1200 G	2.22	8.40	13
1200 DW	2.3	8.71	14
1300 G	2.32	8.78	13
1600 NDNL	2.1	7.95	6
1900 G	3.02	11.43	13
1900 DW	3.06	11.58	14
2100 DW	3.59	13.59	20
6000 P	4.95	18.74	23.8
700 DP	2.25	8.52	14
1500 DP	3.01	11.39	14
742 HW	2.45	9.27	14
744 HW	3	11.36	28
1600 HZ	2.5	9.46	Top-14; Bottom-6

# COVERS AND PANELS

## TOP FILL COVER

The Top Fill Cover provides access to the Reservoir Tank Cap without the requirement to remove the entire Power Head Lid. Remove the cover to access the Reservoir Tank Cap when the Add Fluid Light is illuminated.

1. Place the Power Toggle Switch to the OFF position.
2. Remove the Philips screws securing the Top Fill Cover.
3. Remove the Top Fill Cover.
4. Reverse the procedure to reinstall the Top Fill Cover.

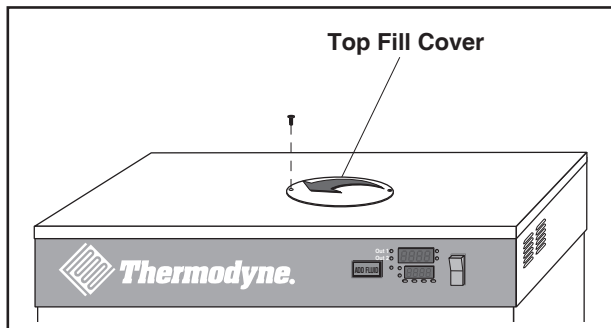

Figure 1: Top Fill Cover

## POWER HEAD LID



### WARNING

**Before removing any sheet metal panels or servicing this equipment, always perform the Electrical LOCKOUT/TAGOUT Procedure. Be sure all circuits are disconnected. Failure to comply with this procedure can cause property damage, injury or death.**

Removing the Power Head Lid provides access to all of the components of the Power Head Assembly.

1. Perform the ELECTRICAL LOCKOUT/TAGOUT procedure.
2. Remove the Philips screws securing the Power Head Lid.
3. Remove the Power Head Lid.
4. Reverse the procedure to reinstall the Power Head Lid.

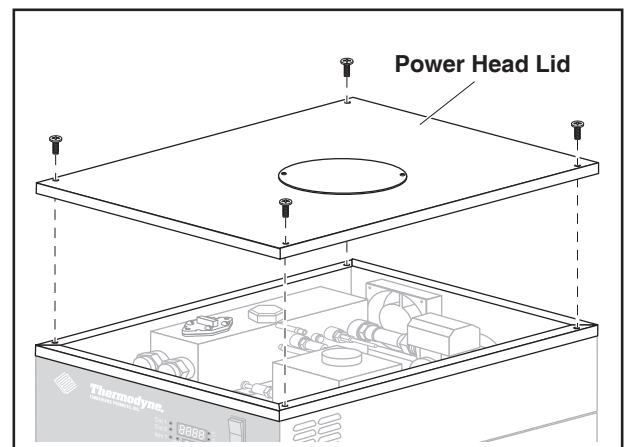

Figure 2: Power Head Lid

---

## SIDE PANELS



### **WARNING**

**Before removing any sheet metal panels or servicing this equipment, always perform the Electrical LOCKOUT/TAGOUT Procedure. Be sure all circuits are disconnected. Failure to comply with this procedure can cause property damage, injury or death.**

The Side Panels provide access to the Fluid Delivery and Fluid Return systems.

1. Perform the ELECTRICAL LOCKOUT/TAGOUT procedure.
2. Using a regular screwdriver turn the Quarter Turn Post counterclockwise until it unlatches.
3. Repeat until all Quarter Turn Posts are loose.
4. Lift the Side Panel up and away from the unit.
5. Reverse the procedure to reinstall the Side Panel.

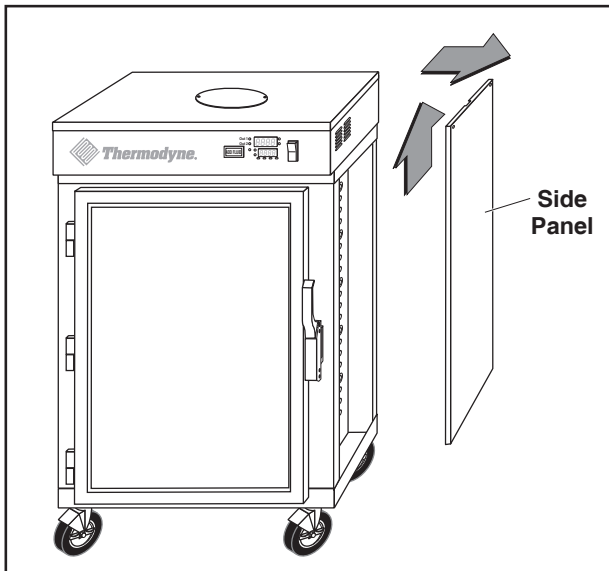

**Figure 3: Side Panel Removal**

## DOORS

All DW, G & P models are supplied with doors that lift off hinges. To remove the doors, open the door slightly and lift it straight up and off the hinge.

---

# COMPONENT LOCATOR

## POWER HEAD COMPONENTS

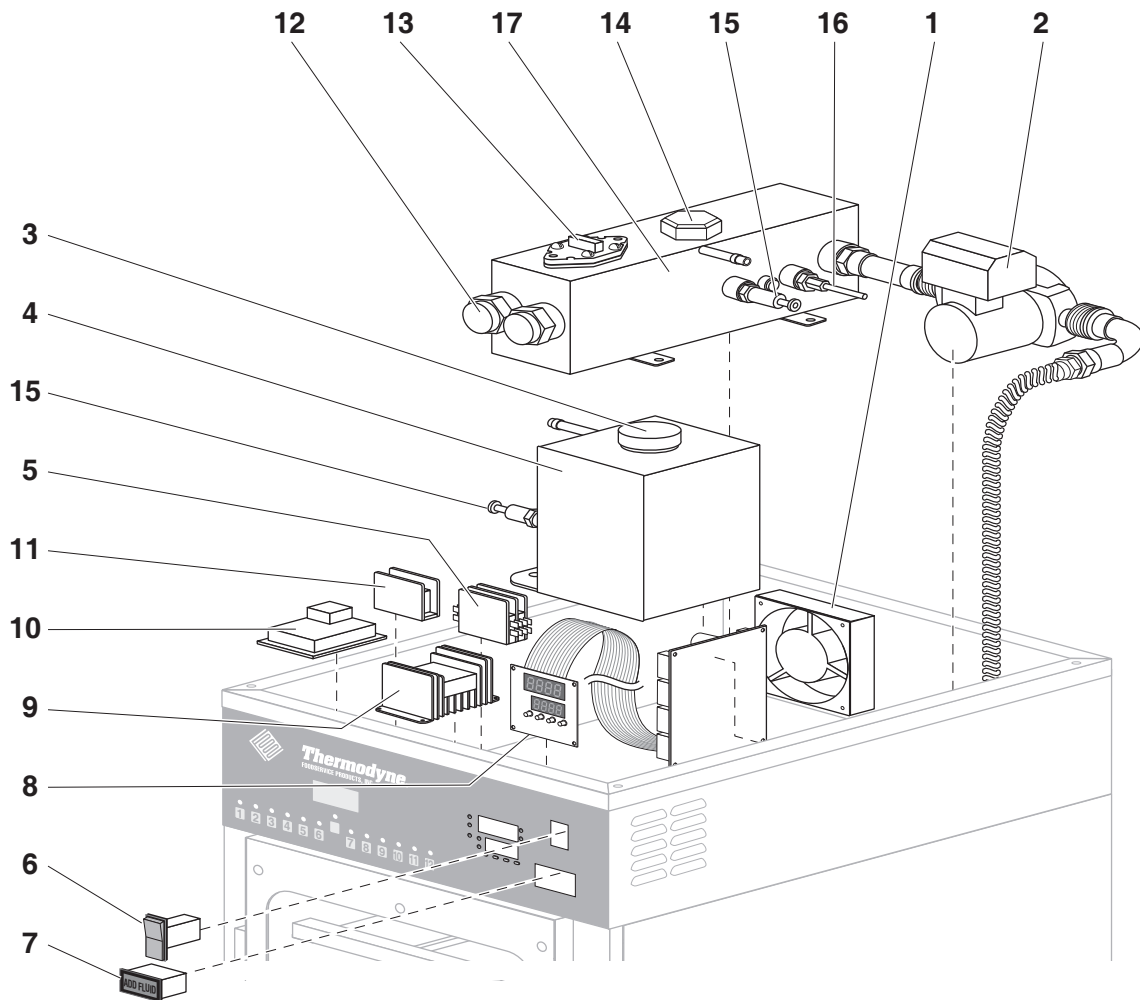
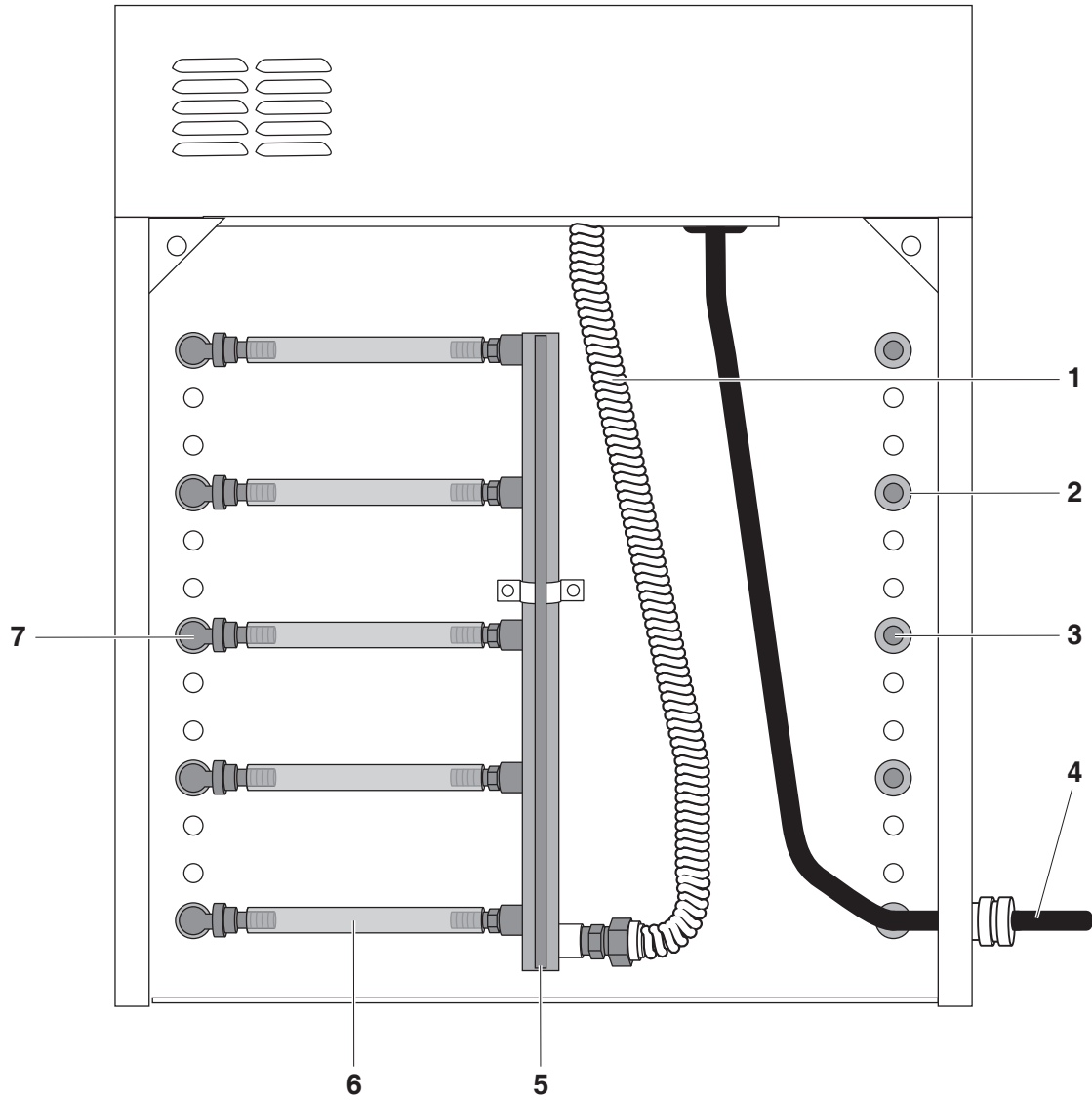

**Figure 4: Power Head Components**

- |                                |                          |
|--------------------------------|--------------------------|
| 1. Cooling Fan                 | 10. 120VAC Float Board   |
| 2. B&G Pump                    | 11. Neutral Lug          |
| 3. Reservoir Fill Cap          | 12. Heater Elements      |
| 4. Reservoir Assembly          | 13. Snap Disc            |
| 5. Contactor                   | 14. 16 PSI Pressure Cap  |
| 6. Lighted Power Toggle Switch | 15. Fluid Level Probes   |
| 7. Add Fluid Light             | 16. Thermocouple         |
| 8. Temperature Controller      | 17. Heater Tank Assembly |
| 9. Solid State Relay           |                          |



## DELIVERY MANIFOLD COMPONENTS



**Figure 5: Delivery Manifold Components**

1. Delivery Line
2. Teflon Washer
3. Shelf Plug
4. Power Cord
5. Delivery Manifold Assembly
6. Short Teflon Hose
7. Shelf Elbow

## RETURN MANIFOLD COMPONENTS

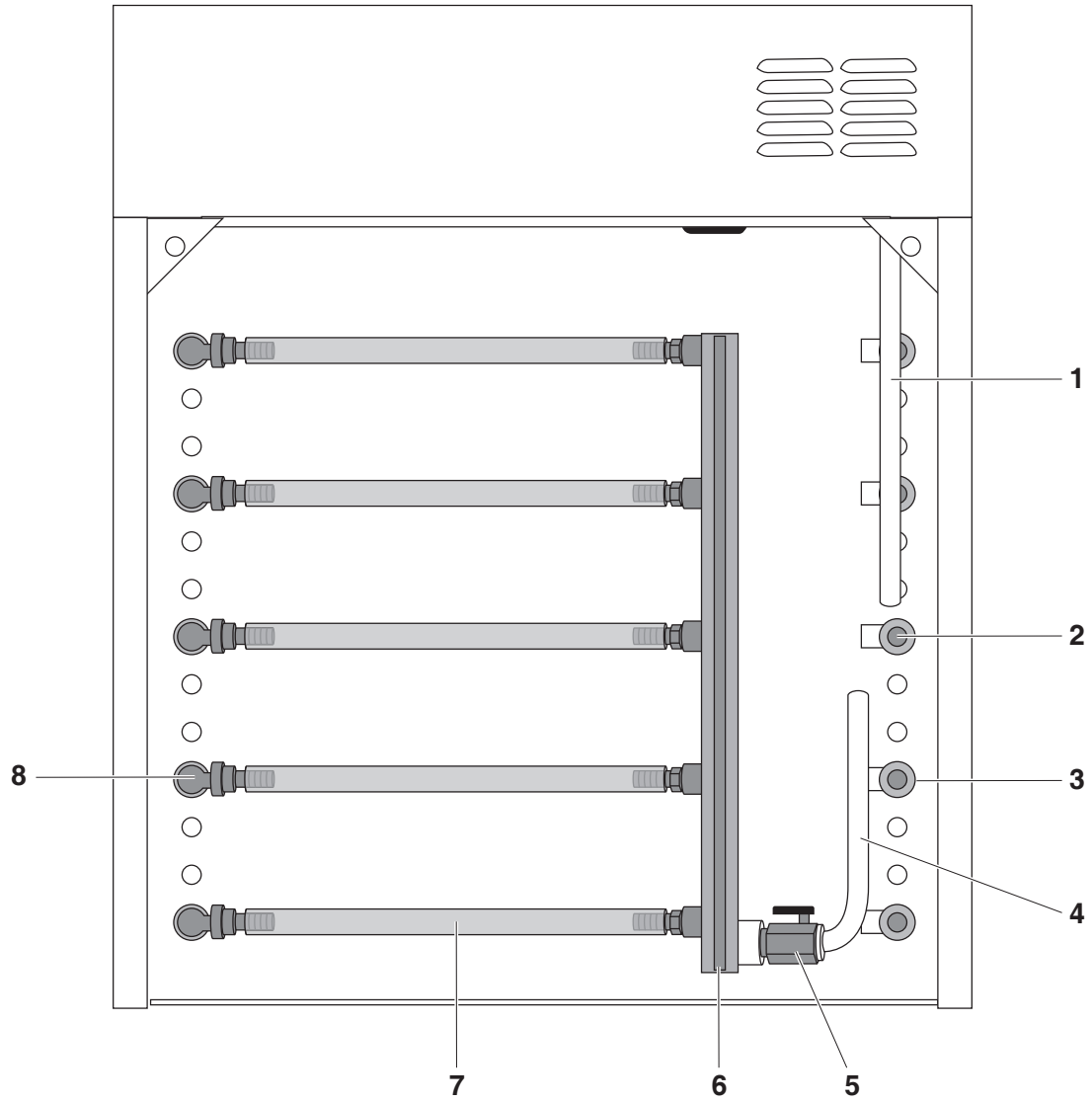

**Figure 6: Return Manifold Components**

1. Overflow Tube
2. Shelf Plug
3. Teflon Washer
4. Drain Tube
5. Drain Tube ON/OFF Valve
6. Return Manifold
7. Long Teflon Hose
8. Shelf Elbow

# COMPONENT REMOVAL AND REPLACEMENT

## ELECTRICAL COMPONENTS



### **WARNING**

Before removing any sheet metal panels or servicing this equipment, always perform the Electrical LOCKOUT/TAGOUT Procedure. Be sure all circuits are disconnected. Failure to comply with this procedure can cause property damage, injury or death.



### **WARNING**

Certain components may be hot if the unit was in operation prior to performing a procedure. *Allow the unit to cool before beginning work.*

## POWER TOGGLE SWITCH

1. Perform the ELECTRICAL LOCKOUT/TAGOUT procedure.
2. Perform the POWER HEAD LID removal procedure.
3. Tag and disconnect the wires connected to the Power Toggle Switch.
4. Squeeze the spring tabs that hold the switch in place and push the switch through the front of the unit.

Note: If the switch being removed is damaged, it may be easier to break the spring tabs off of the switch rather than attempting to squeeze the spring tabs. If this method is used, remember to remove the broken tabs from the inside of the Power Head.

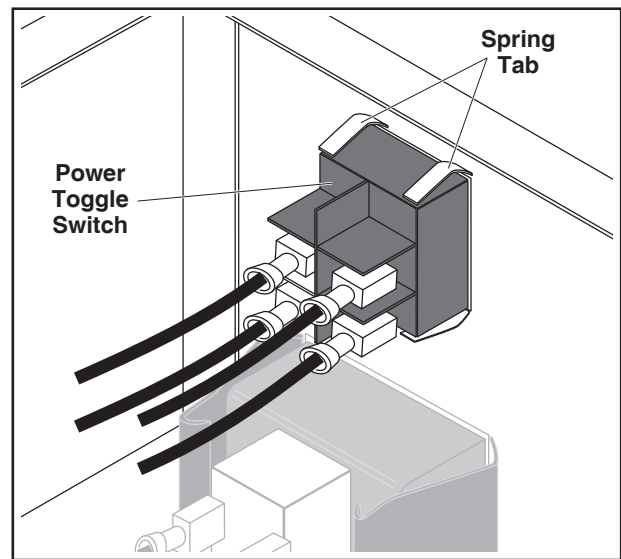

Figure 7: Power Toggle Switch Removal

**CAUTION:** Always use pliers when removing electrical wire connectors. Do NOT pull on the wires to remove the connectors.

5. Insert the new switch through the front of the unit ensuring that the tabs lock into place.
6. Refer to the tags or wiring schematic to reconnect the wires to the new Power Toggle Switch.
7. Restore power to the unit and check the Power Toggle Switch for proper operation.
8. Remove power from the unit.
9. Reverse the POWER HEAD LID removal procedure to reinstall the Power Head Lid.
10. Restore power to the unit and verify proper operation.

## ADD FLUID LIGHT



### **WARNING**

Before removing any sheet metal panels or servicing this equipment, always perform the Electrical LOCKOUT/TAGOUT Procedure. Be sure all circuits are disconnected. Failure to comply with this procedure can cause property damage, injury or death.



## WARNING

Certain components may be hot if the unit was in operation prior to performing a procedure. Allow the unit to cool before beginning work.

1. Perform the ELECTRICAL LOCKOUT/TAGOUT procedure.
2. Perform the POWER HEAD LID removal procedure.
3. Pull the light socket out from the Add Fluid Light cover.
4. Tag and disconnect the two wire connectors.

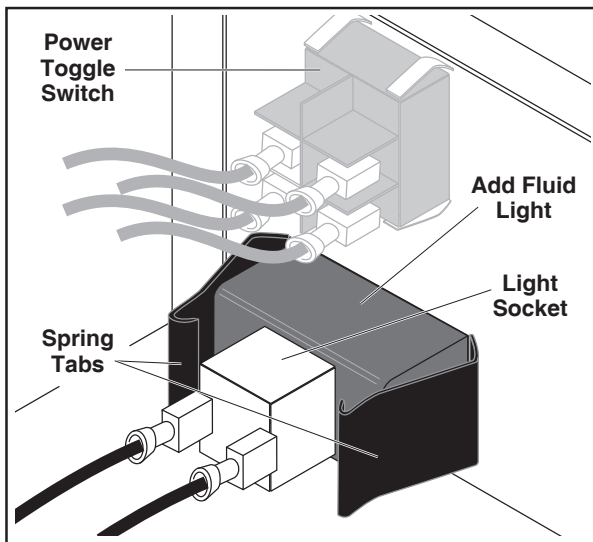

Figure 8: Add Fluid Light Removal

5. Reverse the procedure to reinstall the Add Fluid Light.
6. Restore power to the unit and check the Add Fluid Light for proper operation.

Note: The Add Fluid Light will not illuminate if the Heat Transfer Fluid level is sufficient. Drain fluid as necessary in order to test for proper light operation. Refer to the CHANGING HEAT TRANSFER FLUID procedure for draining and adding Heat Transfer Fluid.

7. Remove power from the unit.
8. Reverse the POWER HEAD LID removal procedure to reinstall the Power Head Lid.
9. Restore power to the unit and verify proper operation.

## TEMPERATURE CONTROLLER

The Temperature Controller consists of two parts: the Controller Main Board (wire harness terminals) and the Display/Pushbutton Board. These two boards are connected by a multi-conductor ribbon cable.

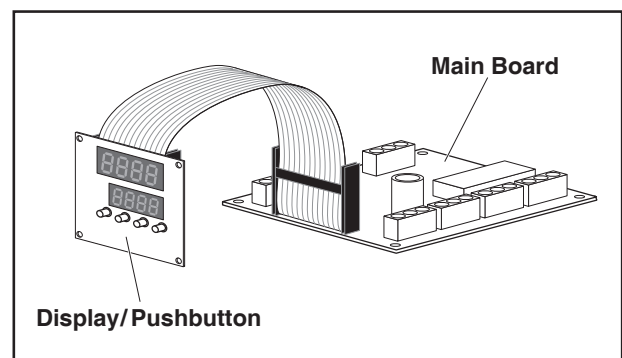
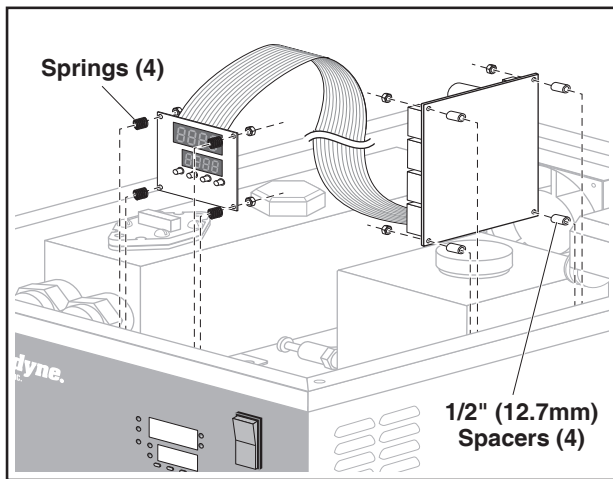

Figure 9: Temperature Controller

1. Follow the LOCKOUT/TAGOUT procedure using the procedures provided in the **Lockout/Tagout Procedures** section of this manual.
2. Remove the Power Head Lid following the instructions provided in the **Panels and Covers** section of this manual.
3. The TBC-41 Controller is very easy to remove. There are four screws and spacers apiece holding the display and power boards. They are different lengths: the spacers used with the power board are 1/2" (12.7mm) long; the spacers used with the display board are 5/16" (8mm) long.



**Figure 10: Temperature Controller Removal**

4. Restore the power and check the controller for proper operation.
5. Remove the unit from its power source and reattach the Power Head Lid.
6. Restore power to the unit and ensure it is operating correctly.

**NOTICE:** The new Temperature Controller may require set up procedures. Refer to the **Temperature Controller Set Up Procedures** section of this manual for set up procedures.

**! WARNING**

Before removing any sheet metal panels or servicing this equipment, always perform the Electrical LOCKOUT/TAGOUT Procedure. Be sure all circuits are disconnected. Failure to comply with this procedure can cause property damage, injury or death.

**! WARNING**

Certain components may be hot if the unit was in operation prior to performing a procedure. Allow the unit to cool before beginning work.

## COOLING FAN

**! WARNING**

Before removing any sheet metal panels or servicing this equipment, always perform the Electrical LOCKOUT/TAGOUT Procedure. Be sure all circuits are disconnected. Failure to comply with this procedure can cause property damage, injury or death.

**! WARNING**

Certain components may be hot if the unit was in operation prior to performing a procedure. Allow the unit to cool before beginning work.

1. Perform the ELECTRICAL LOCKOUT/TAGOUT procedure.
2. Perform the POWER HEAD LID removal procedure.
3. Unplug the leads from the fan.
4. Remove the four screws securing the fan to the Power Head.

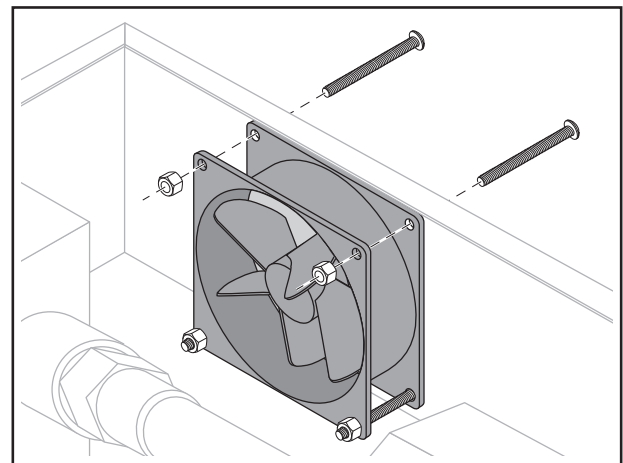

**Figure 11: Cooling Fan Removal**

5. Reverse this procedure to install the new Cooling Fan.
6. Restore power to the unit and ensure it is operating correctly.

## POWER CORD



### **WARNING**

Before removing any sheet metal panels or servicing this equipment, always perform the Electrical LOCKOUT/TAGOUT Procedure. Be sure all circuits are disconnected. Failure to comply with this procedure can cause property damage, injury or death.



### **WARNING**

Certain components may be hot if the unit was in operation prior to performing a procedure. Allow the unit to cool before beginning work.

1. Perform the ELECTRICAL LOCKOUT/TAGOUT procedure.
2. Perform the POWER HEAD LID removal procedure.
3. Disconnect the Power Cord from the Contactor and remove the ground screw securing the green ground wire to the unit frame.
4. Refer to the wiring schematic to connect the new power cord.
5. Restore power to the unit.
6. Verify the unit is working properly.
7. Remove power from the unit.
8. Reverse the POWER HEAD LID removal procedure to reinstall the Power Head Lid.
9. Restore power to the unit and ensure it is operating correctly.

## POWER BOARD COMPONENTS

The Power Board Components include the Solid State Relay, Contactor, Float Board and the Neutral Lug. Under normal circumstances it should not be necessary to replace either the Contactor or the Neutral Lug.

Note: The Power Board is mounted on plastic risers that allow for air to flow on the underside of the board. It is not necessary to remove the Power Board when replacing one of its components; however it may be necessary to loosen the screws that secure the Power Board to the unit. Loosen

but do not remove the screws as they hold the plastic risers in place.

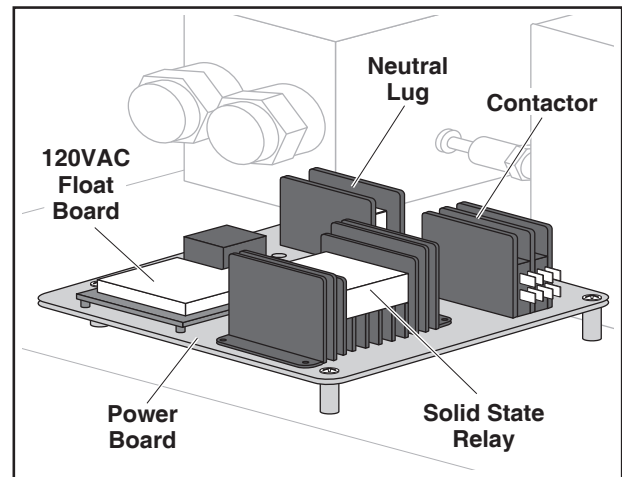

**Figure 12: Power Board Components**

### Solid State Relay



### **WARNING**

Before removing any sheet metal panels or servicing this equipment, always perform the Electrical LOCKOUT/TAGOUT Procedure. Be sure all circuits are disconnected. Failure to comply with this procedure can cause property damage, injury or death.



### **WARNING**

Certain components may be hot if the unit was in operation prior to performing a procedure. Allow the unit to cool before beginning work.

1. Perform the ELECTRICAL LOCKOUT/TAGOUT procedure.
2. Perform the POWER HEAD LID removal procedure.
3. Tag and disconnect the wires to the Solid State Relay.
4. Remove the Solid State Relay by removing the two screws securing it to the Power Board. It may be necessary to loosen the screws securing the Power Board to gain access to the screws at the front of the Solid state Relay.

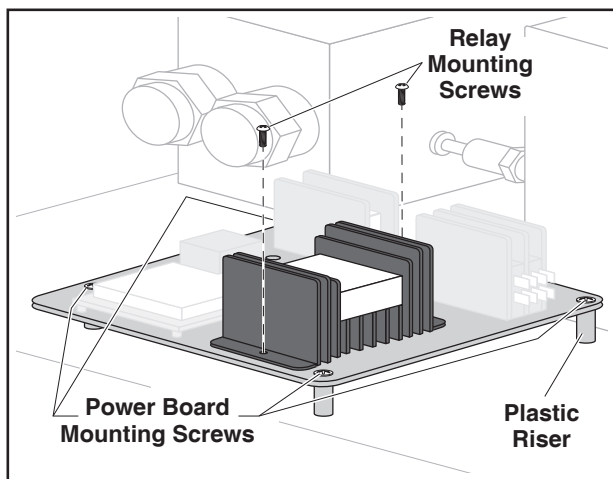

**Figure 13: Solid State Relay Removal**

5. Install the new Solid State Relay.
6. Reattach the screws securing the Power Board to the unit.
7. Refer to the tags or the wiring schematic to reconnect the wires to the new Solid State Relay.
8. Restore power to the unit and verify operation.
9. Reverse the POWER HEAD LID removal procedure to reinstall the Power Head Lid.
10. Restore power to the unit and ensure it is operating correctly.

### Float Board



#### **WARNING**

Before removing any sheet metal panels or servicing this equipment, always perform the Electrical LOCKOUT/TAGOUT Procedure. Be sure all circuits are disconnected. Failure to comply with this procedure can cause property damage, injury or death.



#### **WARNING**

Certain components may be hot if the unit was in operation prior to performing a procedure. Allow the unit to cool before beginning work.

1. Perform the ELECTRICAL LOCKOUT/TAGOUT procedure.
2. Perform the POWER HEAD LID removal procedure.
3. Tag and disconnect the wires attached to the Float Board.

Note: It is NOT necessary to loosen the Power Board screws to gain access to the Float Board.

4. Remove the screws and plastic risers securing the Float Board to the Power Board and lift the Float Board out of the unit.

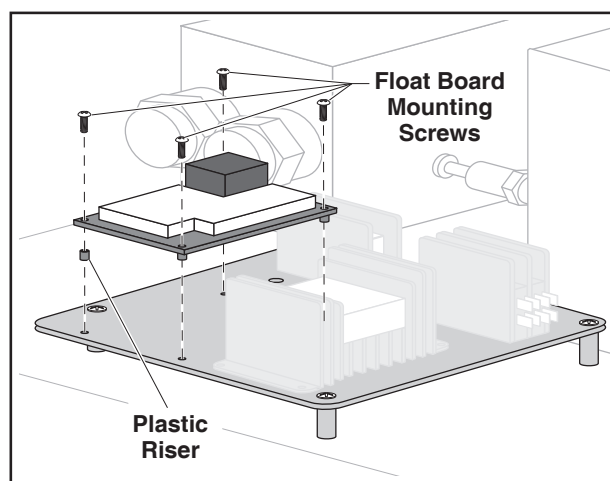

**Figure 14: Float Board Removal**

5. Install the new Float Board making sure a plastic riser is attached to each screw.
6. Refer to the tags or the wiring schematic to reconnect the wires to the new Float Board.
7. Restore power to the unit and check it for proper operation.
8. Remove power from the unit.
9. Reverse the POWER HEAD LID removal procedure to reinstall the Power Head Lid.
10. Restore power to the unit and ensure it is operating correctly.

## PLUMBING COMPONENTS

### B&G Pump



#### **WARNING**

Before removing any sheet metal panels or servicing this equipment, always perform the Electrical LOCKOUT/TAGOUT Procedure. Be sure all circuits are disconnected. Failure to comply with this procedure can cause property damage, injury or death.



#### **WARNING**

Certain components may be hot if the unit was in operation prior to performing a procedure. Allow the unit to cool before beginning work.



#### **WARNING**

Before servicing the plumbing system the heat transfer fluid must be drained from the system.

Additional tools required for this procedure:

- 1-1/16 Wrench
  - 1-3/8 Wrench
  - 7/16 Wrench
1. Perform the ELECTRICAL LOCKOUT/TAGOUT procedure.
  2. Perform the POWER HEAD LID removal procedure.
  3. Perform the SIDE PANEL removal procedure to remove the left side panel.
  4. Locate the Drain Tube and place it into an empty pan.

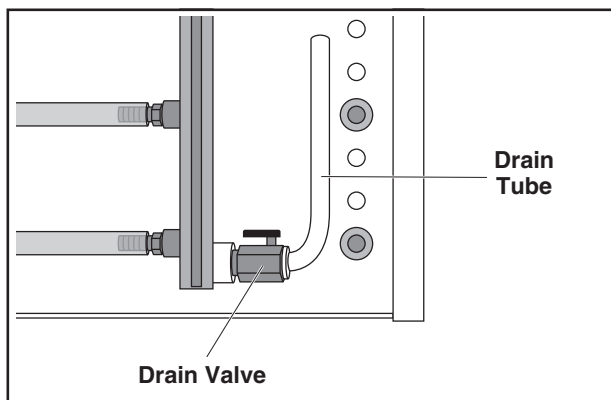

**Figure 15: Drain Tube and Drain Valve Location**

5. Remove both the Heater Tank Pressure and the Reservoir Caps.

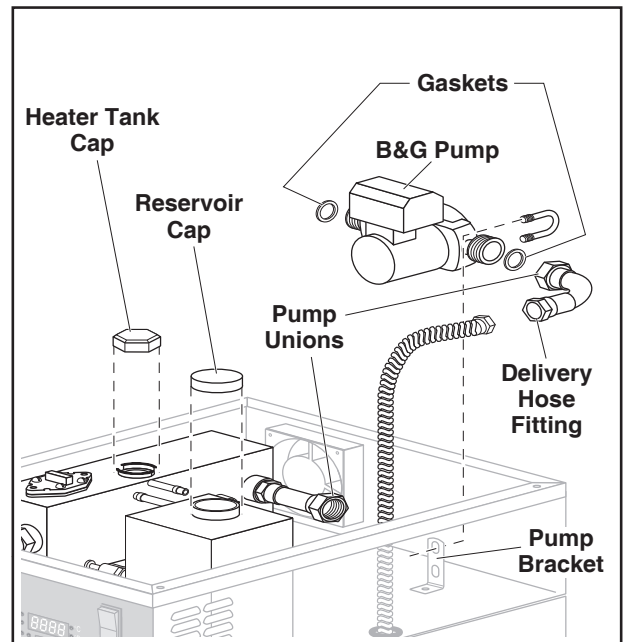

**Figure 16: B&G Pump Removal**

6. Open the Drain Valve to drain the Heat Transfer Fluid.
7. Discard the drained fluid. Refer to the HEAT TRANSFER FLUID MATERIAL SAFETY DATA SHEET provided at the end of this manual for proper disposal of the fluid.
8. Tag and disconnect the B&G pump wires.
9. Using the 1-1/16 wrench, remove the Delivery Line.
10. Using the 1-3/8 wrench, unscrew the unions on both sides of the pump.
11. Using the 7/16 wrench, remove the u-clamp securing the pump to the Pump Bracket and remove the pump.
12. Place the new pump into position.
13. Loosely connect the u-clamp.
14. Ensure NEW gaskets are in place at both unions and tighten the unions using the 1-3/8 wrench.
15. Tighten the 7/16 nuts on the u-clamp.
16. Reconnect the Delivery Line.
17. Refer to the tags or wiring schematic to reconnect the pump wires.



18. Close the Drain Valve.
19. Restore power to the unit.
20. Fill the Heater Tank with FRESH Heat Transfer Fluid and replace Heater Tank Pressure Cap.
21. Fill the Reservoir Tank until the Add Fluid Light goes out and replace Reservoir Tank Cap.
22. Ensure there are no leaks at the pump unions or Delivery Line fittings.
23. Remove power from the unit.
24. Reverse the POWER HEAD LID removal procedure to reinstall the Power Head Lid.
25. Reverse the SIDE PANEL removal procedure to reinstall the panel.
26. Restore the power to the unit and check it for proper operation. It may be necessary to add additional fluid after the unit has operated for several minutes.

### Teflon Hoses



#### **WARNING**

**Before removing any sheet metal panels or servicing this equipment, always perform the Electrical LOCKOUT/TAGOUT Procedure. Be sure all circuits are disconnected. Failure to comply with this procedure can cause property damage, injury or death.**



#### **WARNING**

**Certain components may be hot if the unit was in operation prior to performing a procedure. Allow the unit to cool before beginning work.**



#### **WARNING**

**Before servicing the plumbing system the heat transfer fluid must be drained from the system.**

Under normal operating circumstances it should not be necessary to replace a hose. Should a hose become damaged or begin leaking it must be replaced. There are two sets of Teflon Hoses installed on each unit.

The short Teflon Hoses are located on the delivery side (left side) of the unit. The long Teflon Hoses are located on the return side (right side) of the unit. Both sets of hoses are replaced in the following manner:

1. Perform the ELECTRICAL LOCKOUT/TAGOUT procedure.
2. Perform the POWER HEAD LID removal procedure.
3. Perform the SIDE PANEL removal procedure to remove the applicable side panel.
4. Locate the Drain Tube and place it into an empty pan.
5. Remove Heater Tank Cap and Reservoir Cap.
6. Open the Drain Valve to drain the Heat Transfer Fluid.
7. Discard the drained fluid. Refer to the Heat Transfer Fluid Material Safety Data Sheet provided at the end of this manual for proper disposal of the fluid.
8. Using an open end 3/4 wrench remove the hose from the Shelf Elbow side first.
9. Using an open end 7/16 wrench remove the hose from the manifold.

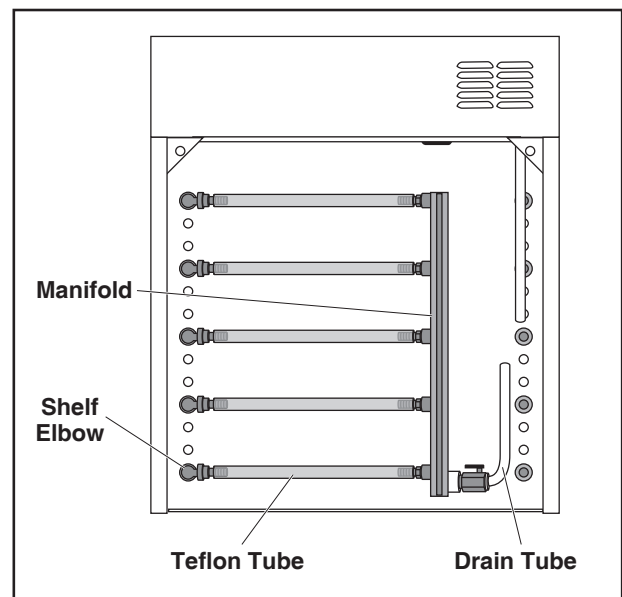

**Figure 17: Return Side of Unit**

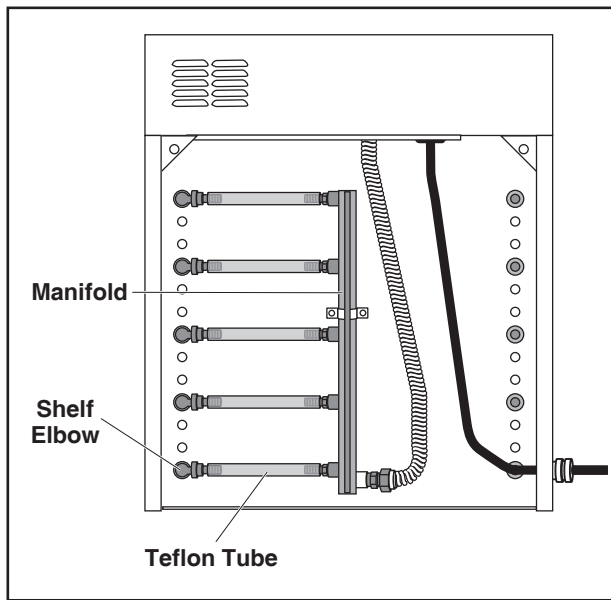

**Figure 18: Delivery Side of Unit**

10. Attach the replacement Teflon Hose to the manifold first, then attach the other end to the Shelf Elbow using the appropriate wrenches.
11. Close the Drain Valve.
12. Restore power to the unit.
13. Fill the Heater Tank with FRESH Heat Transfer Fluid and replace Heater Tank Pressure Cap.
14. Fill the Reservoir Tank until the Add Fluid Light goes out and replace the Reservoir Tank Cap.
15. Ensure there are no leaks around the fittings of the new hose.
16. Remove power from the unit.
17. Reverse the POWER HEAD LID removal procedure to reinstall the Power Head Lid.
18. Reverse the SIDE PANEL removal procedure to reinstall the applicable side panel.
19. Restore power to the unit and check it for proper operation. It may be necessary to add additional fluid after the unit has operated for several minutes.
20. After the unit has operated for several minutes remove the Side Panel where the hose was replaced and ensure that it is not leaking. Tighten as necessary.
21. Reattach the removed Side Panel.

## Fluid Level Probes

### **WARNING**

Before removing any sheet metal panels or servicing this equipment, always perform the Electrical LOCKOUT/TAGOUT Procedure. Be sure all circuits are disconnected. Failure to comply with this procedure can cause property damage, injury or death.

### **WARNING**

Certain components may be hot if the unit was in operation prior to performing a procedure. *Allow the unit to cool before beginning work.*

### **WARNING**

Before servicing the plumbing system the heat transfer fluid must be drained from the system.

There are two Fluid Level Probes. One is installed in the Heater Tank and the other is installed in the Reservoir Tank. Before changing either of the probes, check the fluid levels in the Heater and the Reservoir Tanks. Also, check the electrical connection to the probes. The probes should test as open with a continuity test when the tanks are filled with fluid. With an empty tank the probe should test as closed during a continuity test.

1. Perform the ELECTRICAL LOCKOUT/TAGOUT procedure.
2. Perform the POWER HEAD LID removal procedure.
3. Perform the SIDE PANEL removal procedure to remove the left side panel.
4. Locate the Drain Tube and place it into an empty pan.
5. Remove the Heater Tank Cap and the Reservoir Cap.
6. Open the Drain Valve to drain the Heat Transfer Fluid.
7. Discard the drained fluid. Refer to the Heat Transfer Fluid Material Safety Data Sheet

provided at the end of this manual for proper disposal of the fluid.

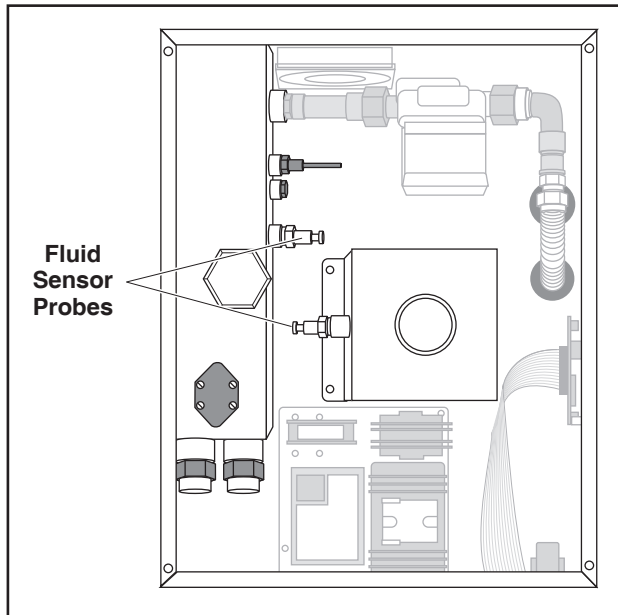

**Figure 19: Fluid Level Probe Removal**

8. Disconnect the Fluid Level Probe lead.
9. Remove the defective probe.
10. Install the new probe.
11. Reconnect the probe lead.
12. Restore power to the unit.
13. Close the fluid Drain Valve.
14. Fill the Heater Tank and Reservoir Tank with fluid until the Low Fluid Light goes out.
15. Ensure that there are no leaks around the newly installed probe, tighten as needed.
16. Remove power from the unit.
17. Reverse the POWER HEAD LID removal procedure to reinstall the Power Head Lid.
18. Reverse the SIDE PANEL removal procedure to reinstall the panel.
19. Restore power to the unit and verify the unit is operating correctly. It may be necessary to add additional fluid after the unit has operated for several minutes.

## SNAP DISC

### **WARNING**

Before removing any sheet metal panels or servicing this equipment, always perform the Electrical LOCKOUT/TAGOUT Procedure. Be sure all circuits are disconnected. Failure to comply with this procedure can cause property damage, injury or death.

### **WARNING**

Certain components may be hot if the unit was in operation prior to performing a procedure. *Allow the unit to cool before beginning work.*

### **WARNING**

Before servicing the plumbing system the heat transfer fluid must be drained from the system.

The Snap Disc is located on the Heater Tank and provides over-temperature protection for the unit.

1. Perform the ELECTRICAL LOCKOUT/TAGOUT procedure.
2. Perform the POWER HEAD LID removal procedure.
3. Perform the SIDE PANEL removal procedure to remove the left side panel.
4. Locate the Drain Tube and place it into an empty pan.
5. Remove Heater Tank Cap and Reservoir Cap.
6. Open the Drain Valve to drain the Heat Transfer Fluid.
7. Discard the drained fluid. Refer to the Heat Transfer Fluid Material Safety Data Sheet provided at the end of this manual for proper disposal of the fluid.
8. Tag and disconnect the Snap Disc wires.

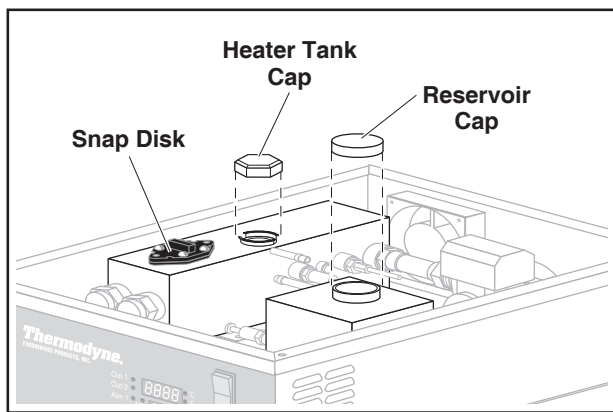

**Figure 20: Snap Disc Location and Removal**

9. Remove the defective Snap Disc.
10. Install the new Snap Disc.
11. Refer to the tags or the wiring schematic to reconnect the wires to the new Snap Disc.
12. Restore power to the unit.
13. Close the fluid Drain Valve.
14. Fill the Heater Tank and Reservoir Tank with fluid until the Low Fluid Light goes out.
15. Ensure that there are no leaks around the newly installed probe, tighten as needed.
16. Remove power from the unit.
17. Reverse the POWER HEAD LID removal procedure to reinstall the Power Head Lid.
18. Reverse the SIDE PANEL removal procedure to reinstall the panel.
19. Restore power to the unit and verify the unit is operating correctly. It may be necessary to add additional fluid after the unit has operated for several minutes.

## THERMOCOUPLE

The Thermocouple is located on the Heater Tank.

**NOTICE:** In BW5SNDNL models the B&G Pump and Heater Tank are located at the back of the unit. Removal of the Back Panel is required when servicing the B&G Pump or Heater Tank Components.

1. Follow the LOCKOUT/TAGOUT procedure using the procedures provided in the **Lockout/Tagout Procedures** section of this manual.

2. Remove the Power Head Lid following the instructions provided in the **Panels and Covers** section of this manual.
3. Remove the left side panel using the procedures provided in the **Panels and Covers** section of this manual.
4. Locate the Drain Tube and place it into an empty pan.
5. Remove the Heater Tank Cap and the Reservoir Cap.
6. Open the Drain Valve to drain the Heat Transfer Fluid.
7. Discard the drained fluid; refer to the **Material Safety Data Sheet** provided in this manual for proper disposal of fluid.
8. The TBC-41 Controller is very easy to remove. There are four springs and spacers apiece holding the display and power boards. They are different lengths: the spacers used with the power board are 1/2" (12.7mm) long; the springs used with the display board are 5/16" (8mm) long.

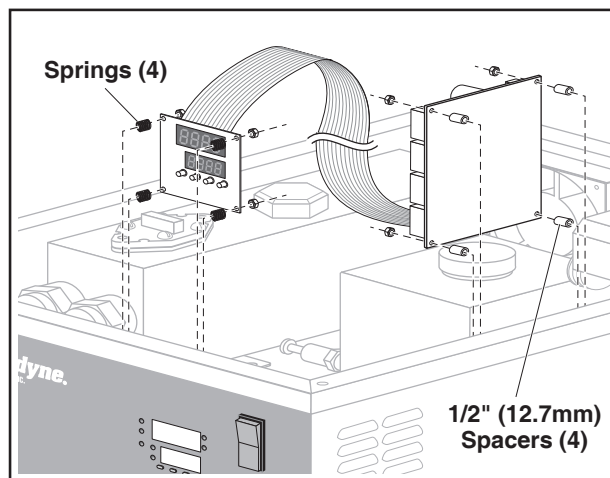

**Figure 21: Controller**

9. Note the location of and colors of the Thermocouple wires on the Controller.
10. Remove the wires for the Controller terminals.
11. Remove the Thermocouple from the Heater Tank.

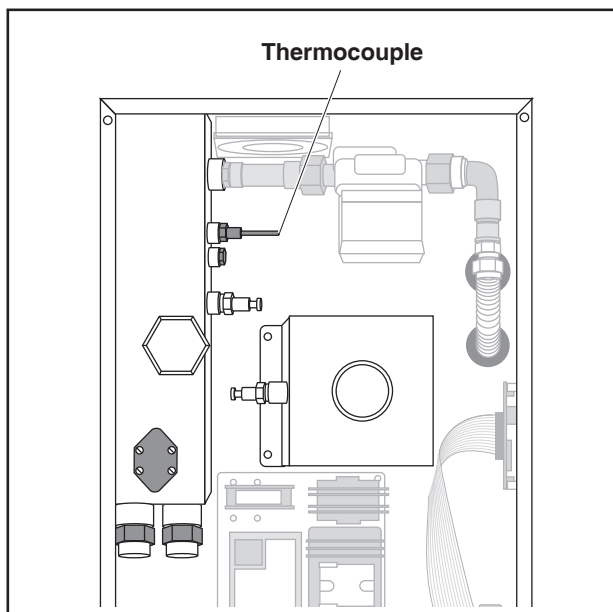

**Figure 22: Location of Thermocouple**

12. Install the new Thermocouple into the Heater Tank; be careful not to damage the Thermocouple lead while performing this task.
13. Referring to the note made in step 9 or the circuit schematic, connect the new Thermocouple leads to the Controller terminals.
14. Restore power to the unit.
15. Close the fluid Drain Valve.
16. Fill the Heater Tank and Reservoir Tank with fluid until the Low Fluid Light goes out.
17. Ensure that there are no leaks around the newly installed Thermocouple, tighten as needed.
18. Remove the unit from its power source.
19. Reattached the Side Panel and Power Head Cover.
20. Restore power to the unit and verify the unit is operating correctly. It may be necessary to add additional fluid after the unit has operated for several minutes.

 **WARNING**

**Before removing any sheet metal panels or servicing this equipment, always perform the Electrical LOCKOUT/TAGOUT Procedure. Be sure all circuits are disconnected. Failure**

to comply with this procedure can cause property damage, injury or death.

 **WARNING**

**Certain components may be hot if the unit was in operation prior to performing a procedure. Allow the unit to cool before beginning work.**

 **WARNING**

**Before servicing the plumbing system the heat transfer fluid must be drained from the system.**

**HEAT ELEMENTS**

 **WARNING**

**Before removing any sheet metal panels or servicing this equipment, always perform the Electrical LOCKOUT/TAGOUT Procedure. Be sure all circuits are disconnected. Failure to comply with this procedure can cause property damage, injury or death.**

 **WARNING**

**Certain components may be hot if the unit was in operation prior to performing a procedure. Allow the unit to cool before beginning work.**

 **WARNING**

**Before servicing the plumbing system the heat transfer fluid must be drained from the system.**

The Heat Elements are located inside the Heater Tank. The Heater Tank must be removed to gain access to the Heat Elements.

Note: Before performing this procedure check each Heat Element with a continuity meter. It is only necessary to replace the faulty element.

1. Perform the ELECTRICAL LOCKOUT/TAGOUT procedure.

2. Perform POWER HEAD LID removal procedure.
3. Perform the SIDE PANEL removal procedure to remove the left side panel.
4. Locate the Drain Tube and place it into an empty pan.
5. Remove Heater Tank Cap and Reservoir Cap.
6. Open the Drain Valve to drain the Heat Transfer Fluid.
7. Discard the drained fluid. Refer to the HEAT TRANSFER FLUID MATERIAL SAFETY DATA SHEET provided at the end of this manual for proper disposal of the fluid.
8. Tag and disconnect Snap Disc Leads.
9. Tag and disconnect Fluid Level Probe wires.
10. Tag and disconnect Heat Element leads.
11. Tag and disconnect Heater Tank ground wire.

Note: It may not be necessary to remove the Thermocouple to change the Heat Elements. If Thermocouple needs to be removed refer to the THERMOCOUPLE removal procedure.

9. Before removing the Heater Tank loosen the Heat Elements with an appropriately sized wrench.
10. Remove the nuts and bolts securing the Heater Tank to the Return Manifold.

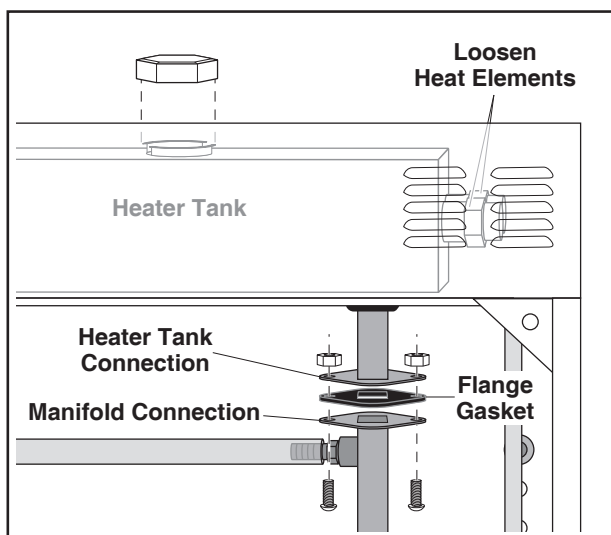

**Figure 23: Heater Tank to Return Manifold Connection**

11. Disconnect the Overflow Tube at the Pressure Cap on the Heater Tank.
12. Completely loosen the Pump Union on the tank side of the pump.
13. Remove the nuts and bolts securing the Heater Tank to the unit's chassis.

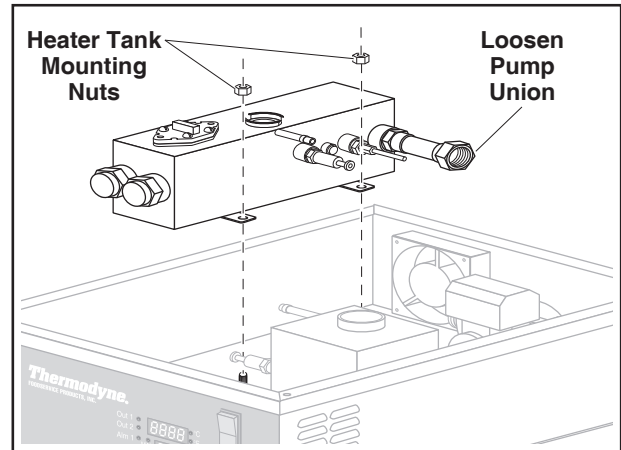

**Figure 24: Heater Tank Removal**

14. Carefully lift the Heater Tank out of the Power Head. If the Thermocouple is still attached be careful not to place undue stress on the Thermocouple wires.

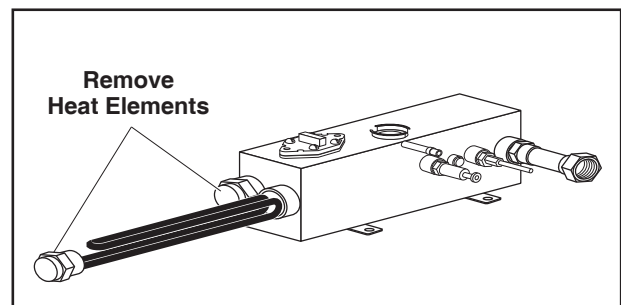

**Figure 25: Heat Element Removal**

15. Unscrew and remove the defective Heat Element.
16. Install the new Heat Element.
17. Using a NEW Flange Gasket reconnect the Heater Tank to the Return Manifold.
18. Reattach the Heater Tank to the Power Head chassis.
19. Tighten the Heat Element that was replaced.
20. Using a new Pump Union Gasket, reconnect the pump to the tank.

- 
21. Reconnect the Overflow Tube.
  22. Refer to the tags or the wiring schematic to reconnect all of the wires and leads. If the Thermocouple was removed, reinstall it.
  23. Restore power to the unit.
  24. Fill the Heater Tank and Reservoir Tank with fresh Heat Transfer fluid until the Low Fluid Level light goes out.
  25. Check for leaks at the Return Manifold Flange, Pump Union, Heat Element and the Thermocouple if it was removed. Tighten as needed.
  26. Remove power from the unit.
  27. Reverse the POWER HEAD LID removal procedure to reinstall the Power Head Lid.
  28. Reverse the SIDE PANEL removal procedure to reinstall the panel.
  29. Restore power to the unit and verify the unit is operating correctly. It may be necessary to add additional fluid after the unit has operated for several minutes.

# MAINTENANCE PROCEDURES

## TEMPERATURE CONTROLLER SET UP PROCEDURES

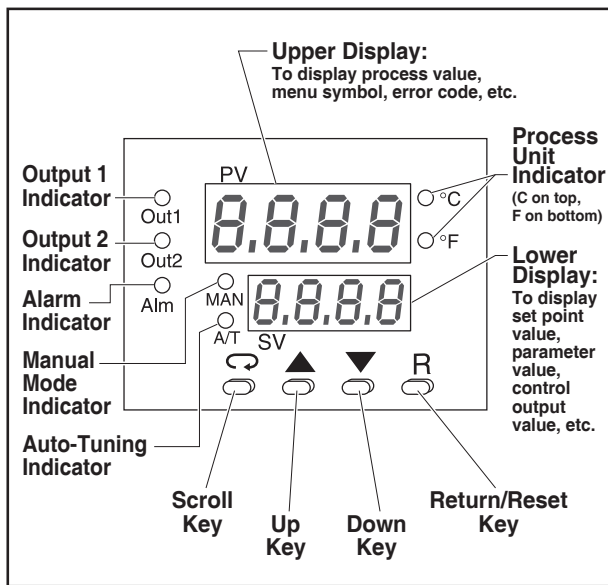

Figure 26: Controller

### Keypad Operation

#### Scroll Key:

This key is used to select a parameter to be viewed or adjusted.

#### Up Key:

This key is used to increase the value of the selected parameter.

#### Down Key:

This key is used to decrease the value of the parameter.

#### Return / Reset Key: **R**

This key is used to:

1. Return the display to indicate the Process Value (PV) and Set Value (SV).
2. Reset a Latching Alarm once the alarm condition has cleared.
3. Discontinue Manual Control, Auto-Tuning and Calibration Modes.
4. Clear error messages indicating communication and auto-tuning errors.
5. Re-set the dwell timer function.
6. Enter the manual control menu if the sensor has failed.

### Set Up

1. Press the “Up” and “Down” key as needed to adjust the displayed set-point temperature.
2. The “OUT1” LED will be lit up solid during warm up. (normal operation)
3. When the “OUT1” LED is blinking, the unit has reached the desired temperature.

NOTE: This controller is not an indicator of fluid level in the Heater or Reservoir Tanks.

### To Toggle Between °F and °C Readout:

1. Press the “Scroll” key 2-3 times until the upper display reads: “unit”
2. Press the “Up” or “Down” key to choose.

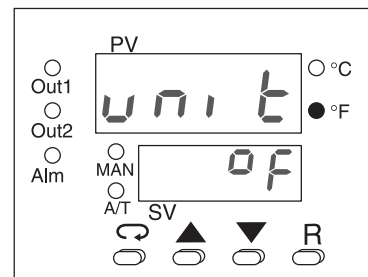

### CHANGING THE HEAT TRANSFER FLUID

#### **WARNING**

Before removing any sheet metal panels or servicing this equipment, always perform the Electrical LOCKOUT/TAGOUT Procedure. Be sure all circuits are disconnected. Failure to comply with this procedure can cause property damage, injury or death.

#### **WARNING**

Certain components may be hot if the unit was in operation prior to performing a procedure. *Allow the unit to cool before beginning work.*





## WARNING

Before servicing the plumbing system the heat transfer fluid must be drained from the system.

The Thermodyne Heat Transfer Fluid has lubricating additives, anti-corrosion additives, and heat transfer properties that protect the Thermodyne cabinet and help maintain the superior heat transfer capabilities of the system. Thermodyne recommends that the Thermodyne Heat Transfer Fluid be changed every 2 to 3 years under normal operating conditions – please consult with the a factory representative for more frequent changes when operating at above normal temperatures (i.e. 200 degrees) or extended hours of operation (i.e. 24/7).

NEVER SUBSTITUTE THERMODYNE HEAT TRANSFER FLUID WITH WATER OR OTHER LIQUID

1. Perform the ELECTRICAL LOCKOUT/TAGOUT procedure.
2. Perform POWER HEAD LID removal procedure.
3. Perform the SIDE PANEL removal procedure to remove the left side panel.
4. Locate the Drain Tube and place it into an empty pan.

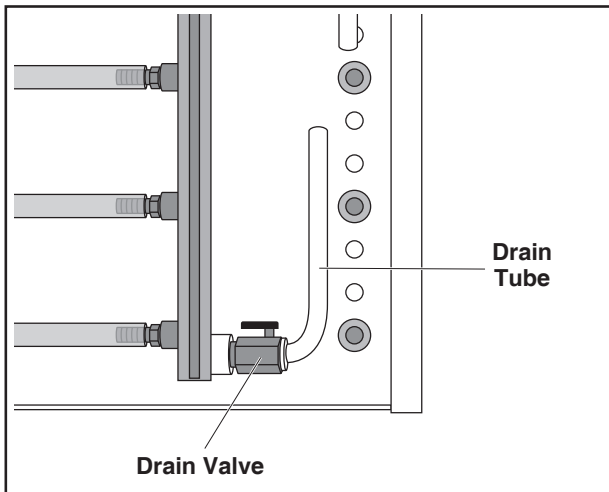

Figure 27: Drain Tube and Valve Location

5. Remove Heater Tank Cap and Reservoir Cap.

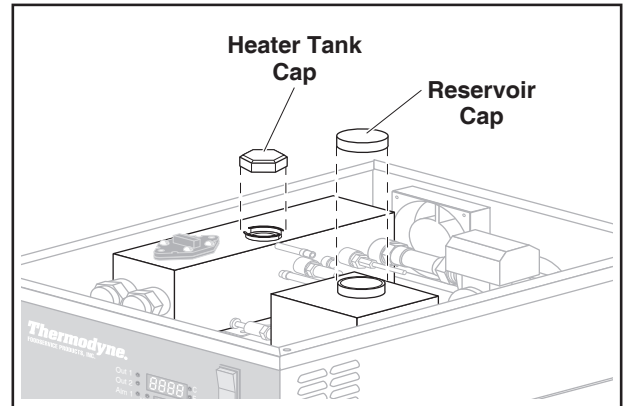

Figure 28: Heater Tank and Reservoir Cap Location and Removal

6. Open the Drain Valve to drain the Heat Transfer Fluid.
7. Discard the drained fluid. Refer to the Heat Transfer Fluid Material Safety Data Sheet provided at the end of this manual for proper disposal of the fluid.
8. Close the Drain Valve and stow the Drain Tube inside the cabinet.
9. Reverse the SIDE PANEL removal procedure to reinstall the left side panel.
10. Reverse the POWER HEAD LID removal procedure to reinstall the Power Head Lid.
11. Restore power to the unit and turn it on.
12. Fill Heater Tank and replace Pressure Cap.
13. Fill the Reservoir until the Add Fluid Light goes out and replace the Reservoir Cap.
14. The Add Fluid Light may come on after a few minutes of operation.
15. Remove the Fill Cap Cover on the Power Head Lid and the Reservoir Cap.
16. Add fluid to the Reservoir until the Add Fluid Light goes out.
17. Reattach the Fill Cap Cover to the Power Head Lid.
18. It may be necessary to add additional fluid after the unit has operated for several minutes.

---

## DOOR ADJUSTMENT

1. Perform the ELECTRICAL LOCKOUT/TAGOUT procedure.
2. **Allow the unit to cool.**
3. Perform the SIDE PANEL removal procedure to remove the side panels.
4. Lift the door(s) up and off of the unit.
5. Loosen the hinges on the unit.

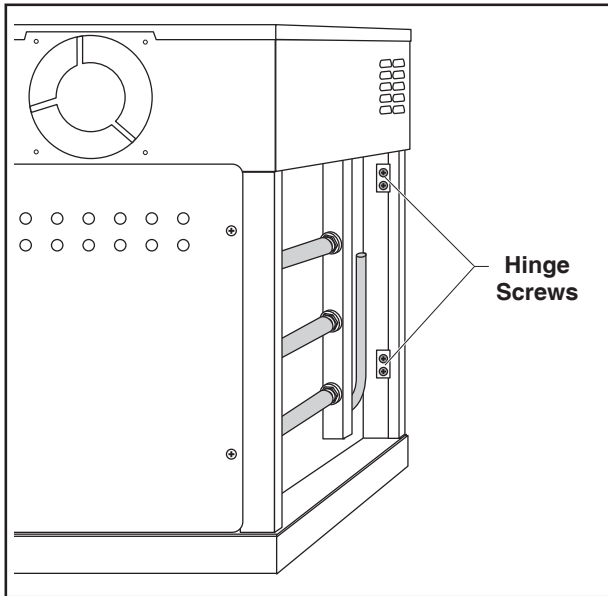

**Figure 29: Location of Door Hinge Screws**

7. Reattach the door(s) to the loosened hinges.
8. Close the door(s) and align them in the closed position.
9. Tighten the hinge screws.
10. Make sure the doors open and close properly.
11. Reverse the SIDE PANEL removal procedure to reinstall the side panels.
12. Restore power to the unit.

---

## STAINLESS STEEL CARE

### Cleaning

Stainless steel contains 70-80% iron, which will rust if not properly maintained. It also contains 12-30% chromium, which forms an invisible passive, protective film that shields against corrosion. If the film remains intact, the stainless steel will remain intact. However, if the film is damaged, the stainless steel can break down and rust. To prevent stainless steel breakdown, follow these steps:

#### **CAUTION**

Never use any metal tools. Scrapers, files, wire brushes or scouring pads (except for stainless steel scouring pads) will mar the surface.

#### **CAUTION**

Never use steel wool, which will leave behind particles that rust.

#### **CAUTION**

Never use acid-based or chloride-containing cleaning solutions, which will break down the protective film.

#### **CAUTION**

Never rub in a circular motion.

#### **CAUTION**

Never leave any food products or salt on the surface. Many foods are acidic. Salt contains chloride.

For routine cleaning, use warm water, mild soap or detergent and a sponge or soft cloth. For heavy-duty cleaning, use warm water, a degreaser and a plastic, stainless steel or Scotch-Brite pad. Always rinse thoroughly. Always rub gently in the direction of the steel grain.

### Preserving & Restoring

Special stainless steel polishing cleaners can preserve and restore the protective film.

Preserve the life of stainless steel with a regular application of a high quality stainless steel polishing cleaner as a final step to daily cleaning.

If signs of breakdown appear, restore the stainless steel surface. First, thoroughly clean, rinse and dry the surface. Then, on a daily basis, apply a high-quality stainless steel polish according to manufacturer's instructions.

### Heat Tint

Darkened areas, called heat tint, may appear on stainless steel exposed to excessive heat, which causes the protective film to thicken. It is unsightly but is not a sign of permanent damage. To remove heat tint, follow the routine cleaning procedure. Stubborn heat tint will require heavy-duty cleaning.

To reduce heat tint, limit the exposure of equipment to excessive heat.

# TROUBLESHOOTING

<b>Problem</b>	<b>Probable Cause</b>	<b>Suggested Solution</b>
No Power	Power Toggle Switch Off Unit not plugged in Circuit Breaker off or tripped Contactor Failure	Place Power Toggle Switch in ON position. Ensure unit is plugged into a live receptacle. Check and reset the Circuit Breaker. Replace the Contactor.
On/Off switch illuminated but controller will not illuminate	Heater Tank fluid level low Fluid Level Probe defective	Remove unit from power source and fill Heater Tank to Pressure Cap neck with fresh Heat Transfer Fluid. Determine which Fluid Level Probe is defective and replace it.
Unit continuously shuts down and requires fluid replenishment  – Or –  Add Fluid light illuminates every couple of days	Fluid leak	Remove the unit from power and remove the Power Head Lid and Side Covers. Restore power and place the ON/OFF switch in its ON position. Observe the unit for leaks. Repair leak and top off fluid levels.
Add Fluid light is illuminated but unit is operating normally	Reservoir Tank low on fluid	Top off Reservoir with fresh Heat Transfer Fluid.
Unit not reaching desired temperature	Controller not set to 189°F. Defective Controller	Refer to Temperature Controller Set Up Procedures and set temperature to 189°F. Refer to Temperature Controller removal procedure and replace controller.
OUT light illuminated but unit not heating up	Defective Solid State Relay Defective or tripped Snap Disc	Refer to Solid State Relay removal procedure and replace relay. Note: If relay LED is illuminated check Snap Disc. Reset Snap Disc. If unit fails to warm up, perform the Snap Disc removal procedure and replace the Snap Disc.
Some shelves heat while others remain cold	Shelf or Delivery/Return Hose is plugged.	Replace defective shelf or defective hose. Note: Delivery and Return hoses are different lengths.
Extreme Electrical Load, clicking noise or controller turning on and off	Fluid Level in Heater Tank low Faulty Contactor	Remove unit from power and top off Heater Tank with fresh Heat Transfer Fluid. Replace the Contactor.
Loud Squealing Noise	Defective Pressure Cap or Pressure Cap Gasket Defective B&G Pump	Replace the 16 PSI Pressure Cap. Refer to B&G Pump replacement procedure and replace pump.
Controller reads SBER on top screen	Defective Thermocouple	Refer to Thermocouple replacement procedure and replace the Thermocouple.

# WIRING SCHEMATICS

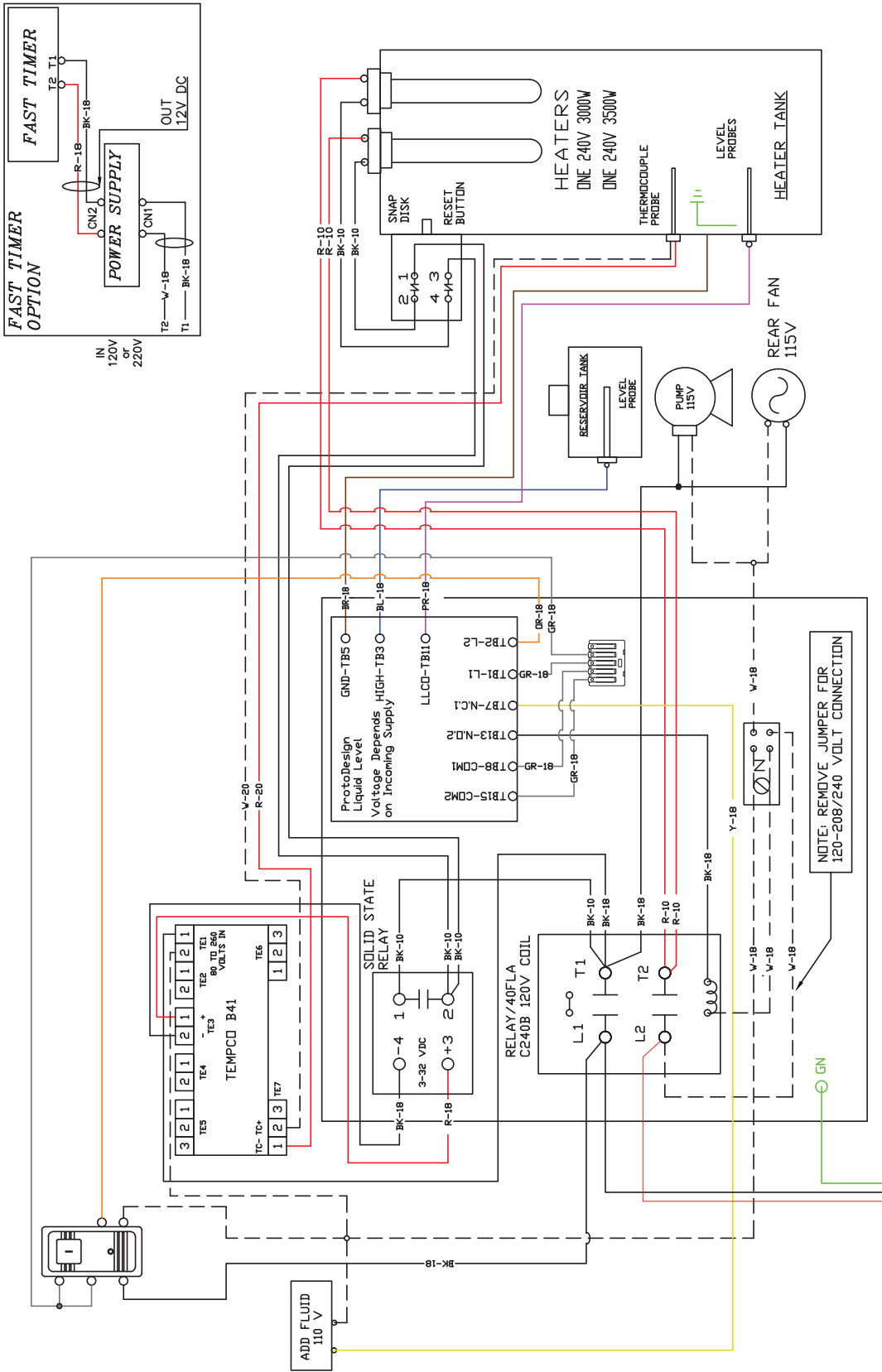

THERMODYNE FOOD SERVICE PRODUCTS INC.	
TITLE STANDARD OVEN WIRING DIAGRAM 120/208/240 VOLT UNITS	
SIZE B	SCALE USA 1-Phase
REV 8	SHEET
DATE: 9-10-21	

**PRIMARY POWER BOARD**

5-15 PLUG FOR USA / 5-20 PLUG FOR CANADA

EDR REFERENCE ONLY:  
 POWER CORD 3-WIRE 12 GA. - 15 AMP  
 POWER CORD 4-WIRE 10 GA. - 26 AMP

TO POWER BOARD TERMINALS

L1 L2 N  
 BK WH GN  
 120 VOLT SUPPLY

L1 L2 N  
 BK R V GN  
 208/240 VOLT SUPPLY

NOTE: REMOVE JUMPER FOR 120-208/240 VOLT CONNECTION

Standard Wiring

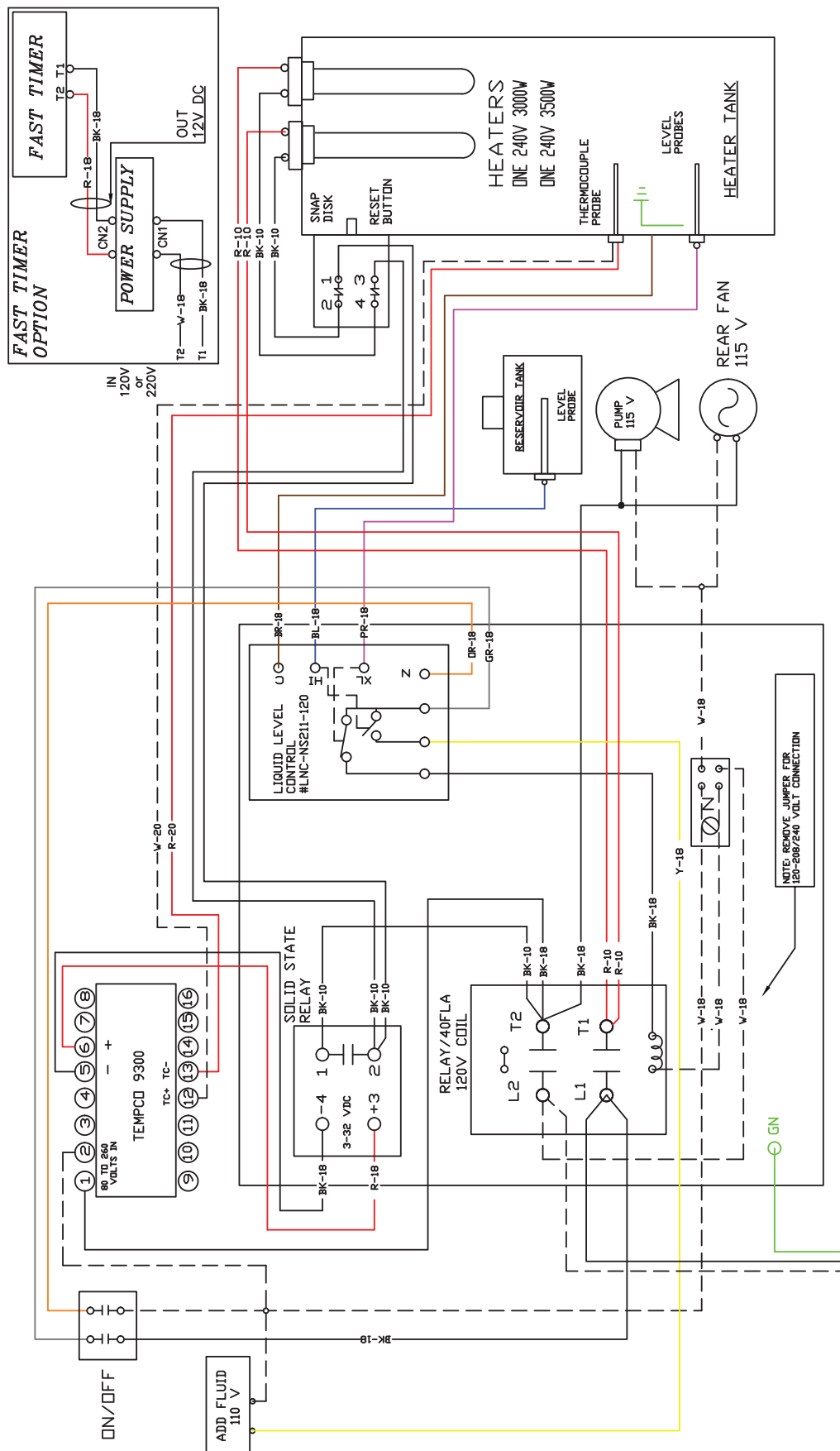

PRIMARY  
POWER BOARD

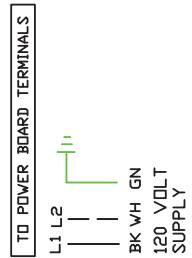

STANDARD 120 VAC WIRING

Standard 120 VAC Wiring

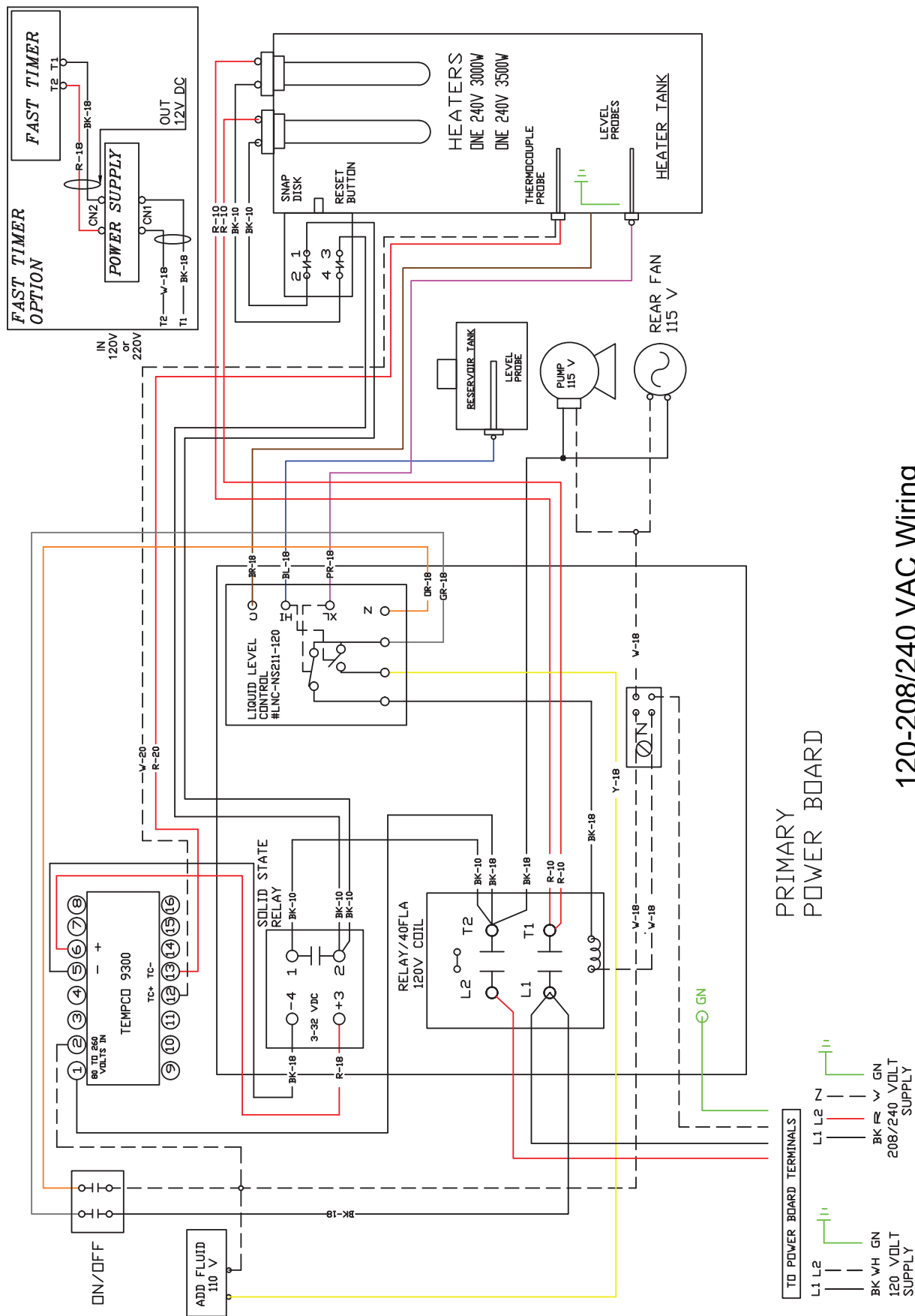

120-208/240 VAC Wiring

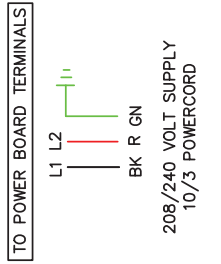
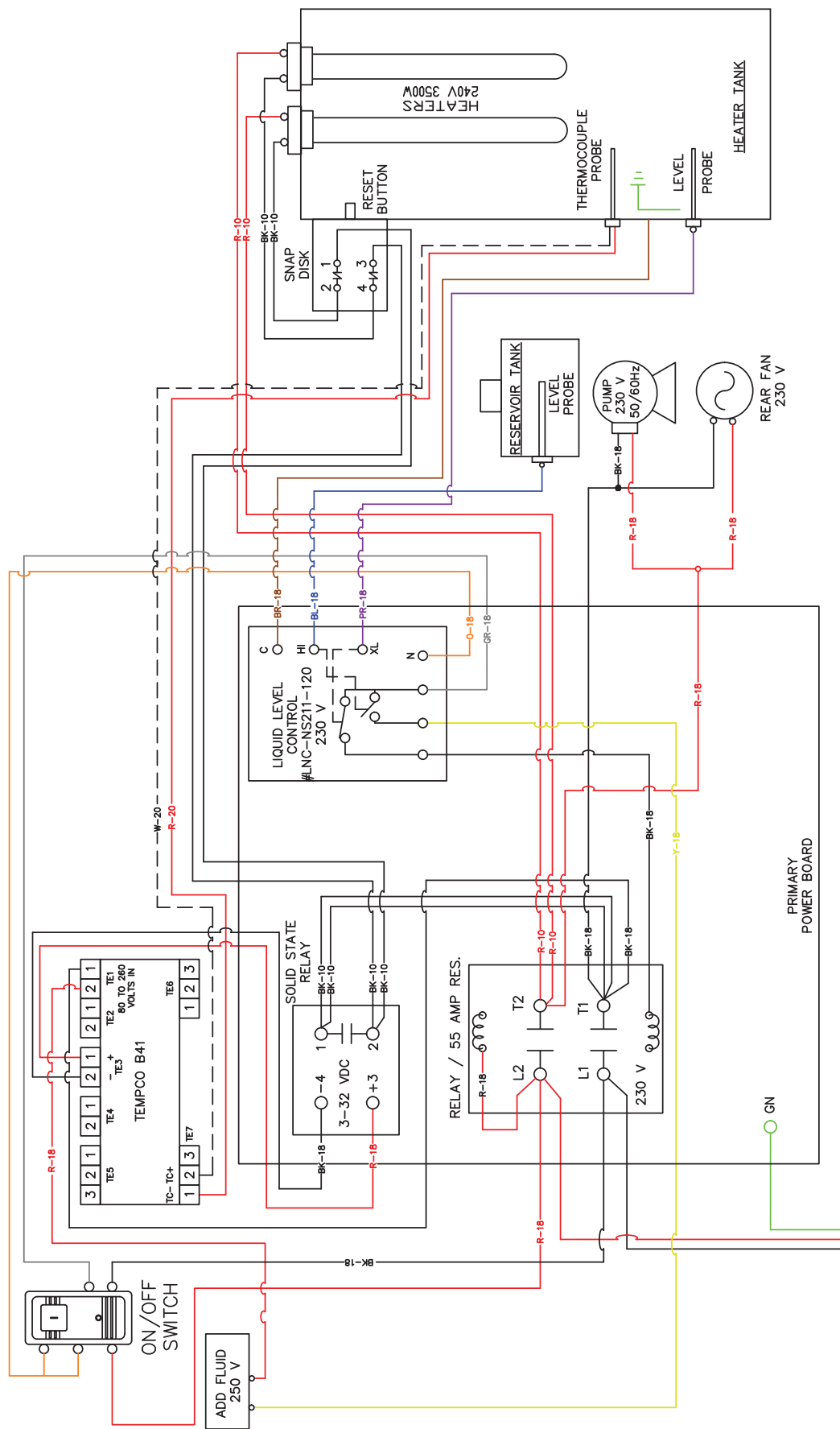

# 3000P

## 3000P Wiring



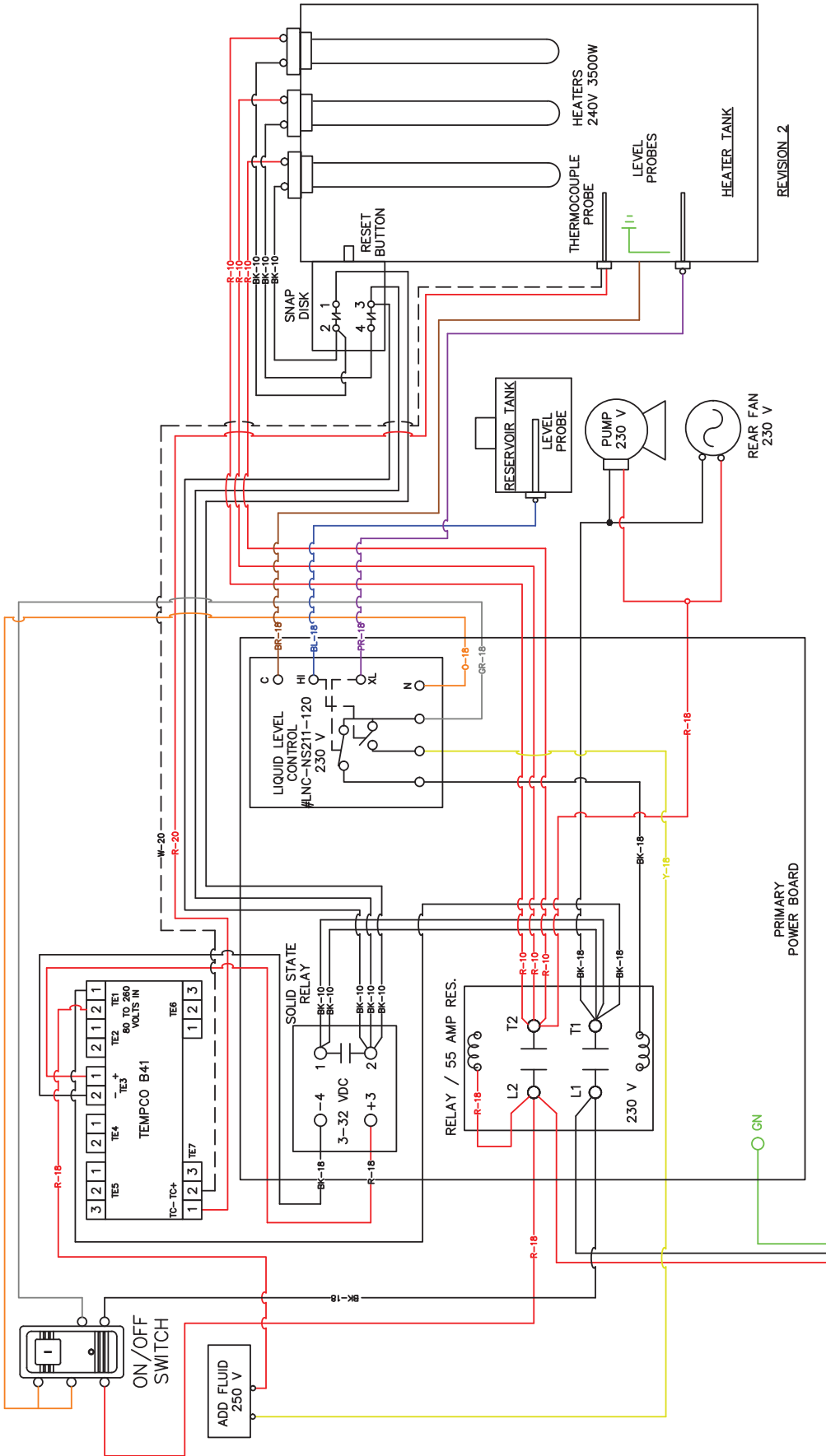

REVISION 2

# 6000P

TO POWER BOARD TERMINALS

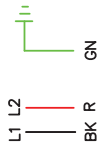

208/240 VOLT SUPPLY  
8/3 POWERCORD

## 6000P Wiring

## WARRANTY

Thermodyne Foodservice Products, Inc. warrants to the original purchaser for use of each new Thermodyne Conductive Cooking/Holding Oven the following: Any part which proves to be defective in materials or workmanship within the warranty period will, subject to the terms of this warranty, be repaired or replaced at Thermodyne Foodservice, Inc.'s option. Claims under this warranty must be presented to Thermodyne Foodservice Products, Inc. in writing, promptly.

Thermodyne stainless steel cabinets are warranted for 5 years and all other original equipment parts such as heat transfer plates, doors, casters, fluid system components and electrical components are warranted against defect for one year from the date of purchase.

This warranty applies only to Thermodyne Conductive Cooking/Holding Ovens in the Continental United States. This warranty shall not apply if the unit or any part is subjected to accident, casualty, alteration, misuse, abuse, neglect, faulty installation, or if the date of manufacture is altered or removed. Thermodyne will cover service agents travel up to 60 miles, any cost associated with travel from over 60 miles will be covered by purchaser.

The obligation of Thermodyne Foodservice Products, Inc. is limited specifically to the aforementioned. No additional guarantees or warranty, expressed or implied, to include without limitation warranties of Fitness or Merchantability with respect to Thermodyne Conduction Ovens and Thermodyne Foodservice Products, Inc. regarding other liability with respect thereto including, without limitation, liability for incidental, special, or consequential damages.

### RESPONSIBILITIES OF PURCHASER

It is the responsibility of the purchaser to:

1. Arrange on site electrical services in accordance with Thermodyne specifications.
2. Receive shipment of Thermodyne conduction unit to include unloading, uncrating, inspecting for damage in shipment, and installation of the unit in its proper location; in accordance with installation instructions.
3. Arrange that the electric services are connected properly by a qualified technician. All such connections must be in accordance with applicable code requirements and Thermodyne installation procedures.

Please note the specific details on the Warranty and make certain that service connections are made to the proper utility services. This warranty and purchasers responsibility information should be retained for future reference.

### For assistance please call:

Toll Free: (800) 526-9182  
Local: (260) 428-2535

## HEAT TRANSFER FLUID MSDS

Dow Chemical U.S.A.  
Midland, MI 48674  
Emergency Phone: 517-636-4400  
Product Code: 23545  
Product Name: PROPYLENE GLYCOL  
HEAT TRANSFER FLUID  
Effective Date: 03-02-88  
Date Printed: 06/02/88  
MSDS: 000130

1. **INGREDIENTS:**  
Propylene glycol CAS# 000057-55-6 95%  
Dipotassium phosphate CAS# 007758-11-4 <5%  
Deionized water CAS# 007732-18-5 <5%

This document is prepared pursuant to the OSHA Hazard Communication Standard (29CFR 1910.1200). In addition, other substances not 'Hazardous' per this OSHA Standard may be listed. Where proprietary ingredient shows, the identity may be made available as provided in this standard.

2. **PHYSICAL DATA:**  
BOILING POINT: 370F, 188C  
VAP. PRESS: 0.22 mmHg @ 20C, 68F  
VAP. DENSITY: 2.62  
SOL. IN WATER; Complete  
SP. Gravity: 1,050 @ 60/60F, 16C  
APPEARANCE: Colorless.  
ODOR: Odorless liquid.
3. **FIRE AND EXPLOSION HAZARD DATA:**  
FLASH POINT: 215F, 102C  
METHOD USED: COC  
FLAMMABLE LIMITS  
LFL: 2.6% @ 100C  
UFL: 12.5% @ 130C  
EXTINGUISHING MEDIA: Water fog, alcohol foam, dry chemical  
FIRE AND EXPLOSION HAZARDS: None.  
FIRE-FIGHTING EQUIPMENT: None.
4. **REACTIVITY DATA:**  
STABILITY: (CONDITIONS TO AVOID)  
Stable over normal  
Operating temperature range of -30F to 250F.  
INCOMPATIBILITY: (SPECIFIC MATERIALS TO AVOID)

Oxidizing material.

- HAZARDOUS DECOMPOSITION PRODUCTS: None  
HAZARDOUS POLYMERIZATION: Will not occur,
5. **ENVIRONMENTAL AND DISPOSAL INFORMATION:**  
ACTION TO TAKE FOR SPILLS/LEAKS: Cover with absorbent material, soak up and sweep into bag.
6. **HEALTH HAZARD DATA:**  
EYE: May cause slight transient eye irritation. Corneal injury is unlikely.  
SKIN CONTACT: Essentially nonirritating to skin on prolonged contact.  
SKIN ABSORPTION: A single prolonged skin exposure is not likely to result in absorption of harmful amounts. The LD50 for skin absorption in rabbits is >10,000 mg/kg.

Repeated exposures may cause slight flaking, tenderness and softening of skin.  
INGESTION: Single does oral toxicity is low. The LD50 for female rats is about 20.3 g/kg

INHALATION: A single prolonged (hours) inhalation exposure is not likely to cause adverse side effects. Mists are not to be hazardous.

**SYSTEMIC & OTHER EFFECTS:**  
Repeated excessive ingestion may cause central nervous system effects. No carcinogenic effects have been seen in long-term animal studies. Birth defects are unlikely. Exposures having no adverse effects on the mother should have no effect on the fetus. In animal studies, has been shown not to interfere with reproduction. Results of mutagenicity tests in vitro (test tube) and in animals have been negative.

7. **FIRST AID**  
EYES: Irrigate immediately with water for at least 5 minutes.  
SKIN: wash off in flowing water or shower  
INGESTION: Induce vomiting if large amounts are ingested, consult medical  
INHALATION: Remove to fresh air if effects occur. Consult medical.  
NOTE TO PHYSICIAN: No specific antidote. Supportive care. Treatment based on judgment of the physician in response to reactions of the patient.
8. **HANDLING PRECAUTIONS:**  
EXPOSURE GUIDELINE (S): Dow IHG is 10mg/m3 for propylene glycol mist. Dow IHG 440 ppm for propylene glycol vapors.  
VENTILATION; Good general ventilation sufficient.  
RESPIRATORY PROTECTION: No respiratory protection should be needed.  
SKIN PROTECTION: No precautions other than clean body covering should be needed.  
EYE PROTECTION: Use safety glasses.
9. **ADDITIONAL INFORMATION:**  
REGULATORY REQUIREMENTS:  
SARAHAZARDCATEGORY: This product has been reviewed according to the EPA 'Hazard Categories' promulgated under Section 311 and 312 of the Superfund Amendment and Reauthorization Act of 1986 (SARA Title III) and is considered, under applicable definitions, to meet the following categories: A delayed hazard.  
SPECIAL PRECAUTIONS TO BE TAKEN IN HANDLING AND STORAGE: Exercise reasonable care and caution.  
MSDS STATUS: Revised Section 9

---

## NOTES

