

Model 742HW combines steam table serving with Thermodyne's Fluid Shelf® technology in one convenient unit. While most steam tables offer little more than wasted space below the unit, Thermodyne provides cooking, holding, and rethermalizing capabilities within the same space, eliminating unnecessary trips to and from the kitchen.



SPECIFICATIONS	
EXTERIOR DIMENSIONS	30.50"W x 30.94"D x 40.50"H
INTERIOR DIMENSIONS	26.50"W x 22.50"D x 20.00"H
CUBIC CAPACITY	6.90ft ³
MAX OPERATING TEMP	230°F
NET WEIGHT	265lbs.
SHIPPING WEIGHT	340lbs.

ELECTRICAL SPECIFICATIONS	
VOLTS	208 / 240
AMPS	20 / 23
TOTAL WATTS	4100 / 5600
HERTZ	60
PHASE †	1
PLUG	NEMA L14-30

SHELVES	
STANDARD	4

CAPACITIES	STANDARD	MAXIMUM*
STEAM TABLE PAN		
12" x 20" x 2.5"	8	8
12" x 20" x 4"	6	6

*Maximum capacities are based on additional shelving. Capacities vary depending on shelf quantities, spacing, and pan depth.

OPTIONS / ACCESSORIES	
Sneeze Guards	Heavy Duty Casters
Stainless Steel Drip Pan	Solid Stainless Steel Doors
Controller Shield	Solid Back Panel

† Available in 3Ø by request

Specifications subject to change without notice.

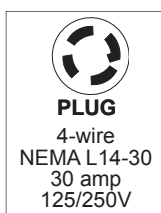
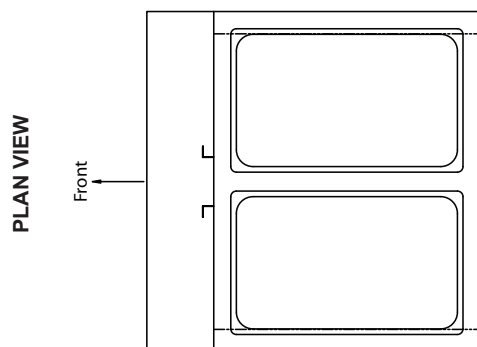
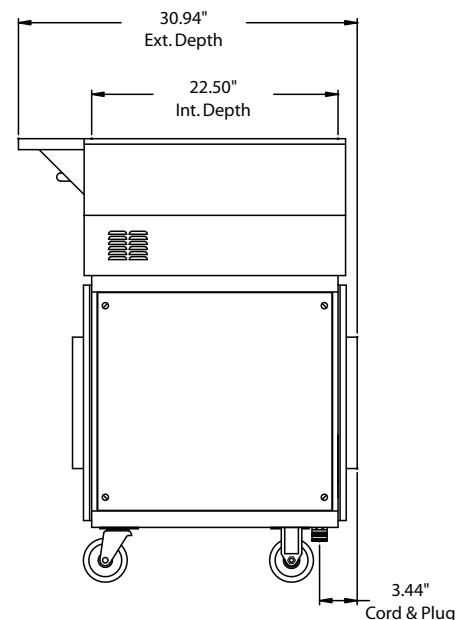
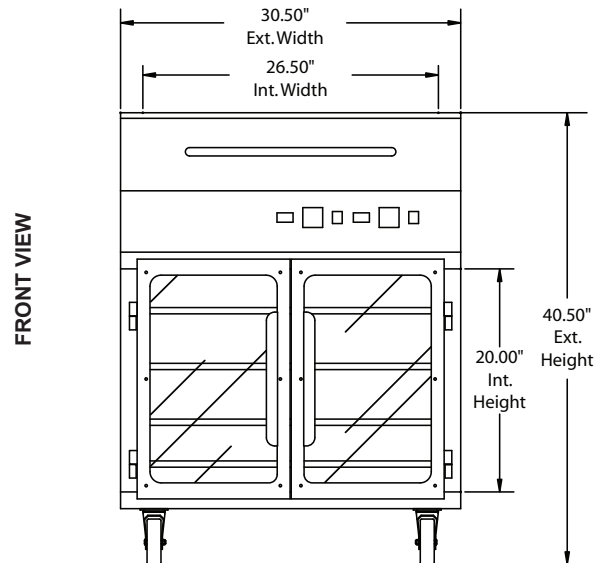

01/12 Patented

Model 744HW combines steam table serving with Thermodyne's Fluid Shelf® technology in one convenient unit. While most steam tables offer little more than wasted space below the unit, Thermodyne provides cooking, holding, and rethermalizing capabilities within the same space, eliminating unnecessary trips to and from the kitchen.



SPECIFICATIONS			
EXTERIOR DIMENSIONS	60.00"W	x 30.94"D	x 40.50"H
INTERIOR DIMENSIONS	56.00"W	x 22.50"D	x 20.00"H
CUBIC CAPACITY	14.58ft ³		
MAX OPERATING TEMP	230°F		
NET WEIGHT	470lbs.		
SHIPPING WEIGHT	560lbs.		

ELECTRICAL SPECIFICATIONS			
VOLTS	208 / 240	208 / 240	
AMPS	25 / 29	23 / 26	
TOTAL WATTS	5250 / 7000	4660 / 6300	
HERTZ	60		
PHASE *	1		
PLUG	NEMA L14-30		

SHELVES	
STANDARD	4

CAPACITIES	STANDARD	MAXIMUM*
STEAM TABLE PAN		
12" x 20" x 2.5"	16	16
12" x 20" x 4"	12	12

*Maximum capacities are based on additional shelving. Capacities vary depending on shelf quantities, spacing, and pan depth.

OPTIONS / ACCESSORIES	
Sneeze Guards	Heavy Duty Casters
Stainless Steel Drip Pan	Solid Stainless Steel Doors
Controller Shield	Solid Back Panel

† Available in 3Ø by request

Specifications subject to change without notice.

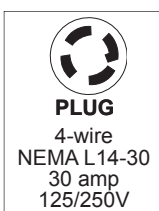
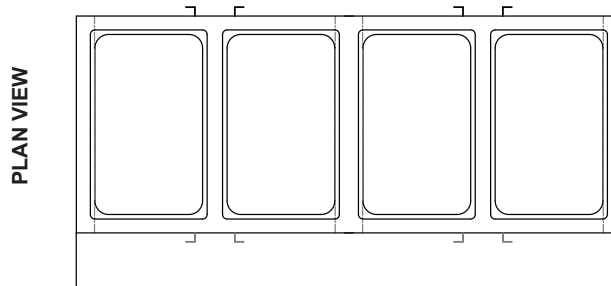
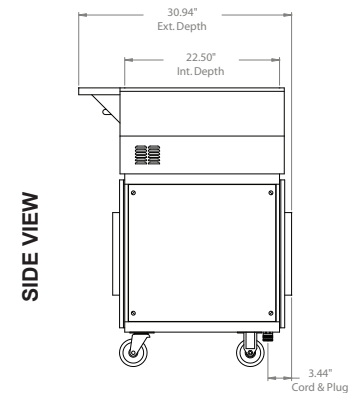
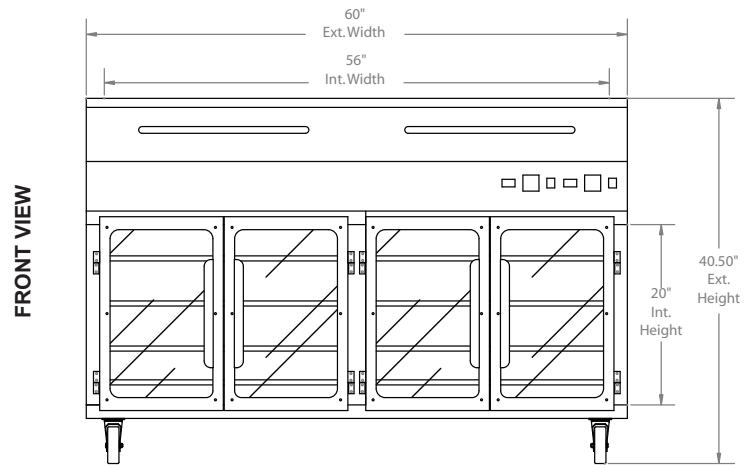

01/12 Patented